



Project _____
 AIA # _____ SIS # _____
 Item # _____ Quantity _____ C.S.I. Section 114000



FD4/500 FOODWASTE DISPOSERS



Complies with
ASSE 1009



SPECIFICATIONS

Motors: Continuous duty rating. Permanently lubricated bearings. Inherent overload protection in motor.

Housings: Heavy-duty ductile iron upper housing. Ductile gray cast iron lower housing, machined, primed and painted. Heavy grind and discharge housings. Four bolts fasten the motor unit to the grind chamber, permit easy removal.

Legs: Tubular stainless steel with flanged feet to support housing. Adjustable to 3" in either direction.

Mounting: Disposer fastens to 7" I.D. throat opening cones. A vinyl isolating ring eliminates metal-to-metal contact at the cone mounting, reduces vibration and noise transmission.

Stationary Shredder Ring: Hardened ductile steel alloy, 1 3/8" high, 24 grinding teeth.

Flywheel: Hardened, ductile steel alloy flywheel with a breaker blade is 10 5/8" diameter. Flywheel outside diameter is cut at a 45° angle. Flywheel can be raised or lowered to adjust cutting gap, adjust for wear to increase life.

Motor Shaft Seal: Three lip seals with slinger on top of motor.

Drain Connector: The removable outlet flange is tapped for 2" pipe connection.

Dual Direction Grinding: Disposer flywheel operates in either direction. When installed with Control Groups 5 & 6, flywheel automatically starts in opposite direction each start. (Increases life and efficiency of grinding elements and frees flywheel of jams.)

Weight: Shipping – approximately 190 lbs. (does not include accessory group or controls).

FD4/500 FOODWASTE DISPOSERS

SPECIFIER STATEMENT

Peak periods for the large food service establishment can be very demanding on any food waste disposer. This powerful disposer has a large capacity for food waste. Hobart has engineered the 5 horsepower unit to perform dependably during peak demands for economical food waste disposal.

Approved by _____ Date _____ Approved by _____ Date _____

ACCESSORY GROUPS

GROUP A



Nitrile Rubber Scrapping Ring



Stainless Steel Silver-Saver Sleeve with Side Feed Hole



Water Swirl



Vacuum Breaker

GROUP B



Nitrile Rubber Silver-Saver Splash Guard Ring



Water Swirl



Vacuum Breaker

GROUP C



Nitrile Rubber Silver-Saver Splash Guard Ring



Vacuum Breaker



Pre-Rinse Spray with Wall Bracket

GROUP D



Nitrile Rubber Silver-Saver Splash Guard Ring



7" I.D. Stainless Steel Weld-in Adapter for Sink



Fixed Direction Water Inlet for Sink



Vacuum Breaker

ACCESSORY COMPONENTS

CONES-SINK – Stainless Steel



Part No.

Cone 15" I.D. w/hole for water swirl inlet.....ML-32664

Cone 18" I.D. w/hole for water swirl inlet.....ML-32666

Cone 15" I.D. w/out swirl hole..... 315144

Cone 18" I.D. w/out swirl hole..... 315146



Sink 16" x 20" x 7" (7" opening) w/hole for water inlet.....ML-32662

WATER INLETS



Cone Water Swirl Inlet
1/2" N.P.T. 315122



Fixed Direction Water Inlet
(for sinks or troughs) 1/2" N.P.T..... 315142

FLOW CONTROL



10 Gallons per minute for Model FD500 – 3/4" N.P.T..... 315150

CONE COVER – STAINLESS STEEL



15" Cone Cover w/feed hole.....ML-33268

18" Cone Cover w/feed hole.....ML-33269

CONE FEEDING ACCESSORIES



Part No.

Nitrile Rubber Scrapping Ring 292122



Stainless Steel Silver-Saver Sleeve with side feed hole 315140

SILVER-SAVER SPLASH GUARD RING



Nitrile Rubber Silver-Saver and Splash Guard Ring (for 7" opening cones, sinks and adapter) 315124

SINK ADAPTER – Standard Group D Accessory



7" I.D. Stainless Steel Adapter for Welding to Sink or Trough 292123

VACUUM BREAKERS – Luster Chrome Plated



1/2" 315138

PRE-RINSE SPRAYS

PR-3 Heavy-duty Flexible Pre-rinse Spray (40" high with wall bracket) ML-32333



Adapters are available to install Hobart Disposers on existing cones. See Form F7543.

ELECTRICAL CONTROL GROUPS

Listed by Underwriters Laboratories Inc., for use with FD3 and FD4 Disposers (50 Hz. Electrical Specifications not submitted for UL Listing.)

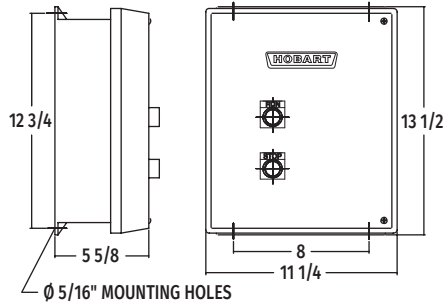

Group 5

Includes:
Magnetic Contactors
Pushbutton Start and Stop
Automatic Reversing
NEMA 4 Enclosure
Solenoid Valve (24 V only)

Approximate
Shipping Wt. 19 lbs.

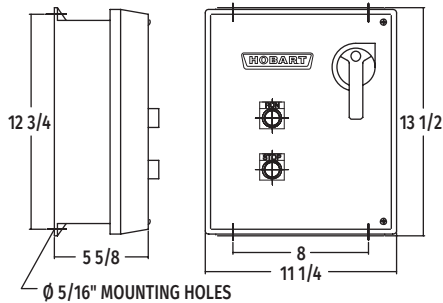

Group 6

Includes:
Magnetic Contactors
Pushbutton Start and Stop
Automatic Reversing
Time Delay for water after shut-off
Line Disconnect
Solenoid Valve (24 V only)
NEMA 4 Enclosure

Approximate
Shipping Wt. 20 lbs.

AVAILABLE ELECTRICAL SPECIFICATIONS

H.P.	Ph.	Hz.	Volts	Rated Amps
5	3	60	200-230/460	14.0 / 7.0
5	3	50	220-240/380-415	13.2 / 6.6

The slant (/) line indicates the dual voltage operation accomplished by motor lead connection: follow connecting diagram on motor.

SAMPLE SPECIFICATION

FD4/500 — B — 5 (230/60/3)

Electrical Specifications

Electrical Control Group

Accessory Group

Model Number

Cut hole 19" for 18" cone. Hole to be 16" for 15" cone.

Solenoid must be installed in upright position.

Disposer may be easily rotated for better drain line connection.

Center line at wall outlet of trap should not be higher than center line of disposer discharge opening.

If water pressure is in excess of 60 P.S.I. install a pressure reducing valve.

DETAILS AND DIMENSIONS

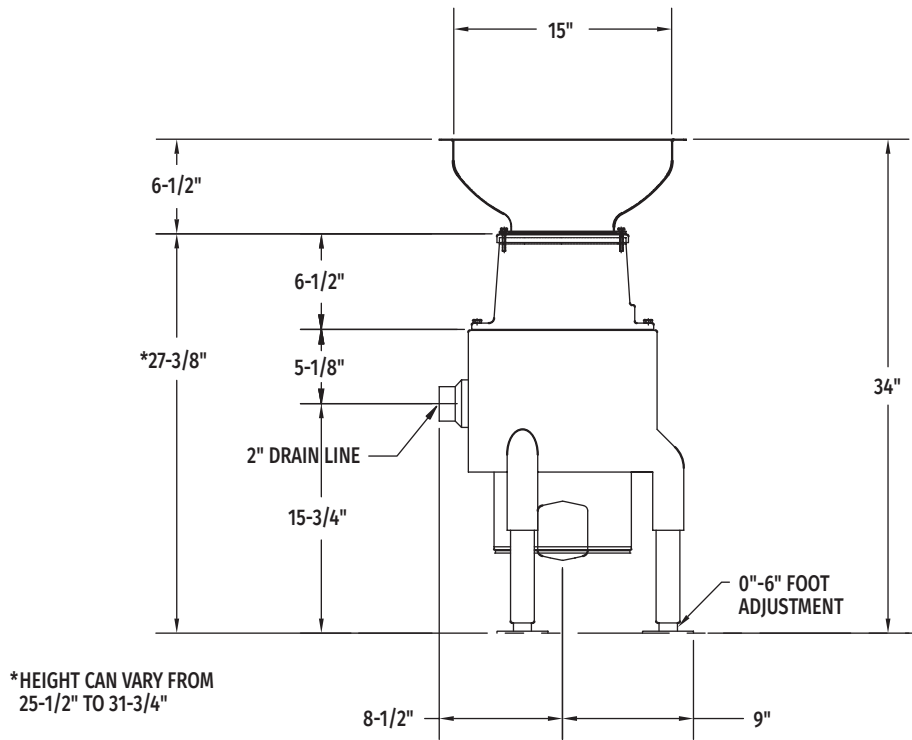

NOTE: Accessory Groups A and B – 18" Cone is Standard.
Specify 15" Cone in Place of 18" Cone When Desired.

TYPICAL INSTALLATION

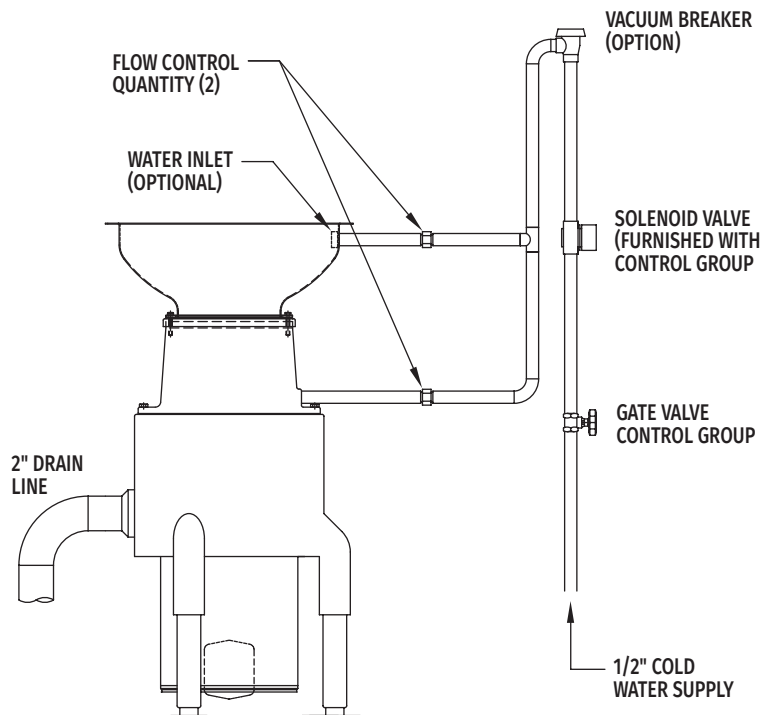

➤ CAD and/or Revit Files Available

As continued product improvement is a policy of Hobart, specifications are subject to change without notice.