

HOBART701 S Ridge Avenue, Troy, OH 45374
1-888-4HOBART • www.hobartcorp.com**FP400i
FOOD PROCESSOR****HOBART****STANDARD FEATURES**

- Gear transmission
- Stainless steel housing
- Two-speed motor
- Triple hopper/cover interlock
- Two stationary front legs and two rear legs with casters for ease of mobility
- Processes up to 88 lbs. per minute
- Plate speeds 240 and 480 RPM

ACCESSORIES

- 3-pack plates (1/16", 5/32" slicer plates, 3/16" shredder plate and wall rack)
- 6-pack plates (same as 3-pack plus 3/8", 7/32" slicer plates, 3/8" dicer plate and additional wall rack)
- 3-peg wall rack (designed to hold 3 plates)
- Stainless steel accessory cart
- Adjustable height stainless steel lug cart
- Stainless steel pan
- Plastic pan
- Over 40 individual plates available
- Stainless steel tray

MODEL

- FP400i-1 (Must also select Feed Hopper Choice)

FEED HOPPER CHOICES

- Cutting Cylinder – 400iPFD-CYL
- Stacking Cylinder – 400iSTK-CYL

Choose one or both:

- Manual Push Feed Assembly – MNL400i-HANDLE
- Tubular Feeder – 400iTB-FEED
- Bulk Feed Hopper and Cylinder – 400iFD-HOPPER (Complete).

Specifications, Details and Dimensions on Reverse Side.

**FP400i FOOD PROCESSOR**

FP400i FOOD PROCESSOR



701 S Ridge Avenue, Troy, OH 45374
1-888-4HOBART • www.hobartcorp.com

SOLUTIONS/BENEFITS

Red OFF, Green ON Button

Ease of use

- Operator can readily recognize

Floor Mount Design

Ease of use, small footprint, reduced labor, increased sanitation and productivity

- Convenient feed height for easy loading
- Plates remove in seconds
- Feed hopper removes without tools for ease of cleaning
- Produces consistent quality product results in seconds
- Two rubber feet for secure setup during use
- Two casters to allow for movement for setup and storage

Planetary Drive

Performance and reliability

- Helps to prevent stalling under heavy loads
- No rest times required between loads

Push Feed Setup

Machine setup with a hopper and manual push handle

- Full moon hopper for large loads
- Ergonomic handle for pushing product into hopper

Tube Feed Setup

With tubular feeder installed into the full moon hopper

- Provides four round tubes for continuous feeding of various long or round products

Bulk Hopper Setup

With bulk feed hopper and cylinder installed

- Allows for gravity feed of round products such as potatoes, turnips, etc.
- High capacity feed for large batches

Rugged Construction

Stainless steel hopper and housing, stainless steel bulk hopper

- Stainless steel finish resists harsh cleaners
- Easy cleanup

Double Interlock Switch

Protection

- Prevents machine from running when pusher plate swings away or is open

Plate Speed

Two speed operation 240 rpm/480 rpm

- Slower speed for good quality processing of more delicate products like tomatoes
- Higher speed for quicker processing of more durable products like potatoes
- Precise cutting and dicing action without bruising or mashing of products

Decorating Screw

Quality, consistency

- Deflects products away from the plate hub for complete processing

SPECIFICATIONS

DESIGN: Compact design with a convenient load height for ease of use. Housing constructed of stainless steel with rubber feet to prevent movement or skidding.

ELECTRICAL: 208-240/60/3, 7.5 amps, 6 foot, 3 conductor power cord (16 AWG). Furnished with NEMA L15-20P locking type plug.

MOTOR: 2 HP two speed motor, 240/480 rpm gear driven transmission.

SWITCHES: Easy to operate (red) OFF and (green) ON switch. Toggle speed selector switch. Pusher plate and hopper are interlocked.

WARRANTY: Unit has full one-year warranty on parts, labor and mileage against manufacturer's defects. Service contracts are available.

CUTTING TOOLS: The plates feature stainless steel construction with cutlery grade stainless steel knives. Plate combinations for dicing are shown in the chart to the right.

WEIGHT: Net - 139 lbs., Feed Cylinder 13 lb., Manual Push Feeder 17 lb., Continuous Feed Hopper 32 lb.

FP400i Food Processor												
	S40DICE-7/32	S40DICE-5/16	S40DICE-3/8	S40DICE-1/2	S40DICE-1/2LOW	S40DICE-5/8	S40DICE-5/8LOW	S40DICE-3/4	S40DICE-3/4LOW	S40DICE-1	S40DICE-1LOW	S3FRY-3/8
3SLICE-1/32-SS												
3SLICE-1/16-SS												
3SLICE-1/8-SS	✓	✓	✓	✓		✓		✓		✓		
3SLICE-5/32-SS	✓	✓	✓	✓		✓		✓		✓		
3SLICE-7/32-SS	✓	✓	✓	✓		✓		✓		✓		
3SLICE-5/16-SS		✓	✓	✓		✓		✓		✓		
3SLICE-3/8-SS			✓	✓		✓		✓		✓		✓
35SFSLC-5/16		✓	✓	✓		✓		✓		✓		
35SFSLC-3/8			✓	✓		✓		✓		✓		
35SFSLC-1/2					✓			✓				
35SFSLC-5/8								✓				



701 S Ridge Avenue, Troy, OH 45374
1-888-4HOBART • www.hobartcorp.com

FP400i FOOD PROCESSOR

FOOD PROCESSOR ACCESSORIES

A wide variety of plates are available to tackle any food processing application. The construction of all accessories makes them dishwasher safe.

Slicer Plates:

Standard Slicing & Crimping Slicing Plates are used for cutting of soft or hard fruits and vegetables. The formed stainless steel plates with stainless steel hub and drive slot provides a strong, rigid mounting for repeatable operation. Cutlery grade stainless steel knives give sharp, reliable, long lasting cuts to any product. The knives are removable for fast, easy, cost effective replacement of these wear items while reusing the plate. Some plates have double knives for higher volume operations. Straight or decorative crinkle cut blades are available. These plates may be used in conjunction with suitable dicing grids for cubing of products.



Soft Slicer Plates:

The Soft Slicer Plates are specifically designed for more delicate fruits and vegetables such as tomatoes, bananas, plantains, kiwi, etc. The plate is machined from a special aluminum alloy designed to withstand dishwasher cleaning. The straight edge knife and plate configuration cleanly cut through the delicate fruits and vegetables without damaging the product. The knife is removable for fast, easy, cost effective replacement of this wear surface while reusing the plate.

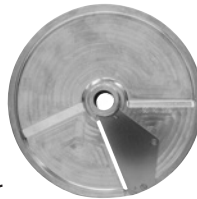

Julienne Plates:

Julienne Cutter Plates are suitable for firm products and are often used for soups, stews, French fries, and decorations. The plate creates long, square, curved strings of product. The formed stainless steel plates with stainless steel hub and drive slot provides a strong, rigid mounting for repeatable operation. Cutlery grade stainless steel knives give sharp, reliable, long lasting cuts. The julienne cutter knife unit is removable for fast, easy, cost effective replacement of these wear items while reusing the plate.



Shredder Plates:

Shredder plates are used for cheese, cabbage, nuts, dry bread, etc. The cast stainless steel frame, hub, and drive slot provide a strong, rigid mounting for repeatable operation.

The stainless steel cutting plate gives sharp shredding action to the product. The cutting plate is removable for fast, easy, cost effective replacement of this wear surface while reusing the mounting frame.

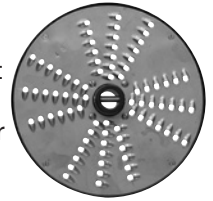

Grater Plates:

Grater plates may be used for hard dry cheese, carrots, potatoes, cabbage, dry bread, etc. The grater plate creates a fine granular/powdery product. The cast stainless steel frame, hub, and drive slot provide a strong, rigid mounting for repeatable operation. The stainless steel cutting plate gives sharp grating action to the product. The cutting plate is removable for fast, easy, cost effective replacement of this wear surface while reusing the mounting frame.

Dicing Grids:

Dicing grids are used in conjunction with slicing plates to produce various sized cube and rectangular shaped products for stews, salads, soups, and a wide variety of other applications. The dicing grid frame is cast stainless steel and provides a strong, rigid mounting for repeatable operation. The grid knives are cutlery grade stainless steel and give sharp cutting action to the product for precise, repeatable control of the product shape. The cutting knife set is removable for fast, easy, cost effective replacement of these wear surfaces while reusing the mounting frame.

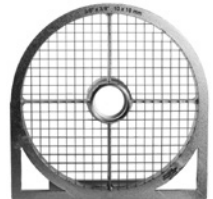

FP400i FOOD PROCESSOR



701 S Ridge Avenue, Troy, OH 45374
1-888-4HOBART • www.hobartcorp.com

DETAILS AND DIMENSIONS

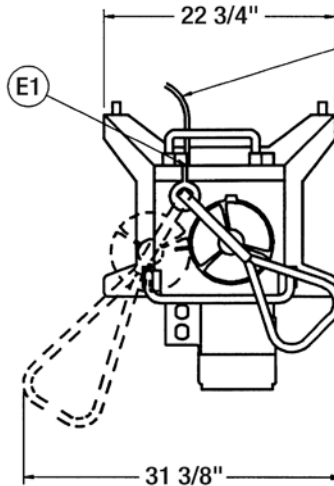
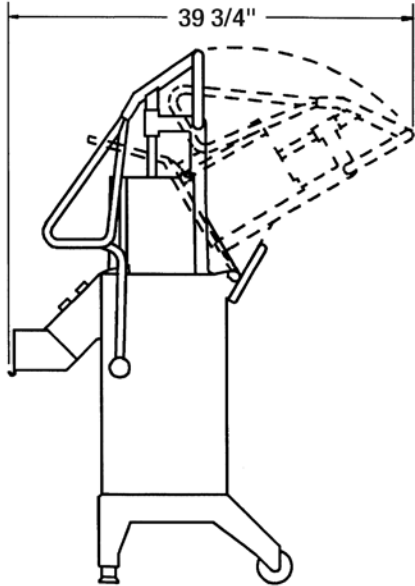

CORD APPROX. 6 FT.
NEMA TYPE L15-20P LOCKING PLUG

Not Pictured:
Tubular Feeder - TUBE-FEED
(Sold Separately)

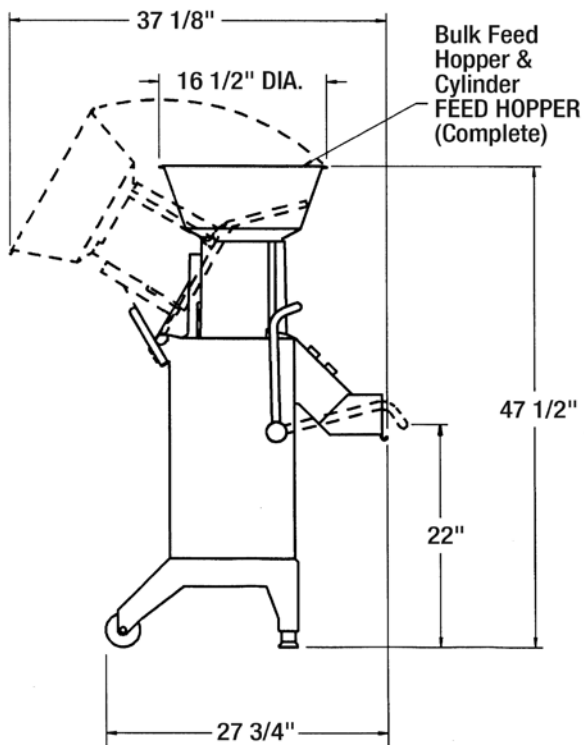

Bulk Feed
Hopper &
Cylinder
FEED HOPPER
(Complete)

Manual Push
Feed Assembly
MNL PFD-HANDLE
(Sold Separately)

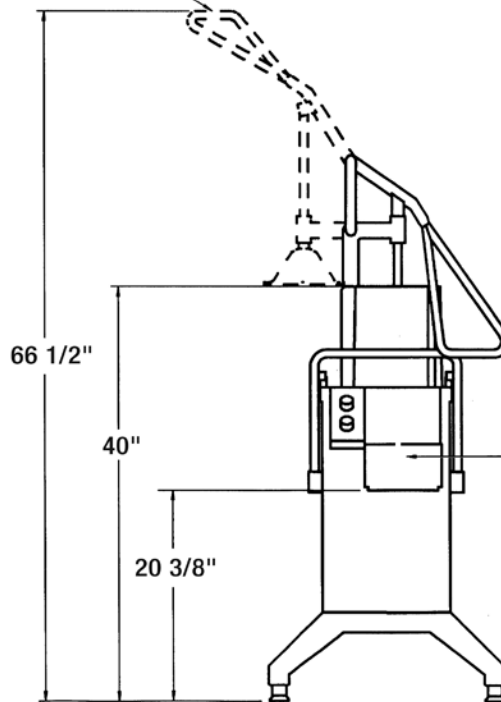

Manual/Tubular
Cylinder
PFD-CYL
(Sold Separately)

As continued product improvement is a policy of Hobart, specifications are subject to change without notice.