

HOBART701 S Ridge Avenue, Troy, OH 45374
1-888-4HOBART • www.hobartcorp.com**CL64T
INDUSTRIAL TOTE WASHER****HOBART****STANDARD FEATURES**

- Selectable Speed 4, 5, 6 feet/minute
- Opti-RinSe™ system
- Rapid return conveyor drive mechanism
- Insulated hinged double doors with door interlock switches
- 19" inch chamber height opening
- Stainless steel vent hoods
- Flanged feet
- Top mounted micro-processor control module
- Energy saver mode
- Dirty water indicator
- Low temperature alert
- Conveyor dwell
- Delime notification
- Service diagnostics
- NAFEM Data Protocol compliant
- Computational fluid dynamic designed self-aligning wash manifolds
- Stainless steel debossed anti-clogging wash arms
- Removable integrated pump intake screen
- Stainless steel self-draining pump and impeller
- Single, sloping scrap screen and deep basket
- Stainless panels enclose perimeter and bottom
- Door actuated drain closure
- Single point electrical connection (three phase only), does not include the booster heater
- Convertible hot water or low temp final rinse
- Vent fan and booster heater control

DIRECTION OF OPERATION

- Right to Left
- Left to Right

VOLTAGE

- 208/60/3
- 240/60/3
- 480/60/3

MODEL

- CL64T

OPTIONS AT EXTRA COST

- Stainless steel pressure-less 15/30 KW booster heater

ACCESSORIES

- High pressure blow off
- Drain water tempering kit

Specifications, Details and Dimensions on Inside and Back.

PLEASE NOTE: Above Floor Finish (AFF) dimension are the same as standard CL64e model for anything below door level. Please add 10.5" to standard AFF dimensions for electrical panel height & overall height dimensions.

**CL64T INDUSTRIAL TOTE WASHER**

CL647 INDUSTRIAL TOTE WASHER

HOBART

701 S Ridge Avenue, Troy, OH 45374
1-888-4HOBART • www.hobartcorp.com

THE CL647 INDUSTRIAL TOTE WASHER IS STANDARD WITH THESE EFFICIENT FEATURES

Inside and out the CL647 Industrial Tote Washers by Hobart are packed with standard components and patented design innovations.



The insulated hinged inspection doors provide easy access in the chamber.



The Hobart exclusive microprocessor control module offers a choice of many features, such as an exclusive Energy Saver Mode, Low Temperature Alerts, and Dirty Water Indicator. It also displays pertinent machine status and has a Delime Notification. The controls have built-in Service Diagnostics and are NAFEM Data Protocol Compliant.



Soil Management System. Screen design sheds soil more easily than flat screens, reduces frequency of cleaning — easy to empty large soil particles . . . Just lift out the scrap basket.

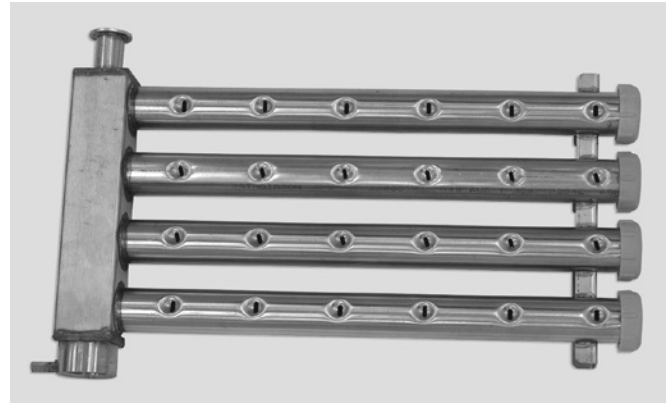

Wash Manifolds. Computational Fluid Dynamic designed wash manifolds are self-aligning and come with Hobart's signature debossed anti-clogging nozzles for superior result.



Opti-RinSe™. Hobart's exclusive Opti-RinSe™ significantly reduces operating cost by reducing rinse water and the energy required to heat the water. The unique spray pattern uses large droplets to more efficiently sanitize the ware.

OTHER STANDARD FEATURES . . .

- **Thermal Layer Curtains** help keep the heat inside the machine.
- **Ball Detent Clutch Conveyor Drive** for maximum protection against conveyor Jams
- **Integrated Removable Pump Intake Screen** to offer the ultimate guard of keeping debris from entering the pump.
- **Hinged Door Seals** and stainless steel labyrinth seal for drip-free operation
- **Low-Temp Convertibility In Field.** All machines shipped hot. Change software in field at set up to low temperature if desired – then, if requirements change, convert from one mode to the other in the field.
- **Door Actuated Drain Closure.** Closing the door automatically actuates drain closure, eliminates extra manual steps, ensures that closure is in the correct position.



701 S Ridge Avenue, Troy, OH 45374
1-888-4HOBART • www.hobartcorp.com

CL64T INDUSTRIAL TOTE WASHER

AVAILABLE OPTIONS AND ACCESSORIES . . .



Built-in Pressureless Stainless Steel Booster Heater. Interwired and interplumbed. Saves on installation and saves floor space. Simplifies operation with just one switch to power machine and booster.



High Pressure Blow-off. Saves on installation and saves floor space. Simplifies operation with just one switch to power machine and booster.

	CL64T
Machine Ratings (Mechanical)	
Conveyor Speed (ft/min)	Selectable 4, 5, 6
Floor Space – Tote Washer (Inches)	108 x 33
Floor Space – with Blow-off (Inches)	166 x 43
Floor Space – Blower and Motor (Inches)	41 x 47
Vertical Space – Tote Washer (Inches)	79
Vertical Space – with Blow-off (Inches)	85
Vertical Space – Blower and Motor (Inches)	50
Motor H.P.	Wash 2 – Rinse 2
Conveyor Drive H.P.	1/8
Number of Tanks	2
Tank Capacity – Gallons	Wash 23 – Rinse 22
Pump Capacity – (gal/min) - Weir Test	Combined 330
Heating Equipment – (For keeping wash zones hot) Gas Burners (with Natural Gas/LP)	156,000 BTU/hr. (2 - 78,000)
Electric Heating Unit – Size Used	Regulated 25 KW (15-10)
Optional Booster Heater / Final Rinse	15 KW / 30 KW
Rinse – Minutes operated during hour of maximum operation	60
Final Rinse Flow – Gals. Per min. At 15/20 PSI Flow Pressure	1.89/2.2
Final Rinse Flow – Gals. per hr. – MAXIMUM At 15/20 PSI Flow Pressure	114/132
Steam Consumption Pounds per hr. - MAXIMUM Approx. 30 lbs. per hr. = 1 boiler H.P. (BHP) Dishwasher, based on 20 PSI steam and on customer supplying final rinse water at 180°F maximum	130
Exhaust Recommendations (ft ³ /min)	
Entrance End	200
Discharge End	400
Peak Rate of Drain Flow – Gallons per minute. (Initial rate with full tank)	38
Shipping Weight Crated – Tote Washer Approximate (lbs)	1000
Shipping Weight Crated – Blow-off Approximate (lbs)	800
Shipping Weight Crated – Blower and Motor – Approximate (lbs)	700

CL64T INDUSTRIAL TOTE WASHER

HOBART

701 S Ridge Avenue, Troy, OH 45374
1-888-4HOBART • www.hobartcorp.com

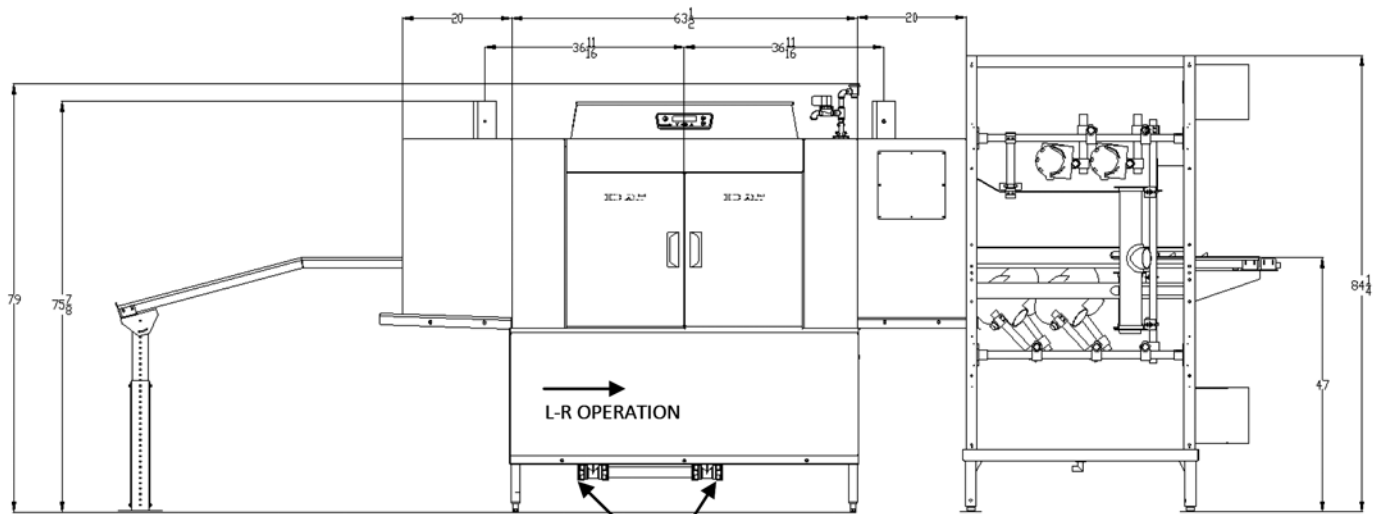
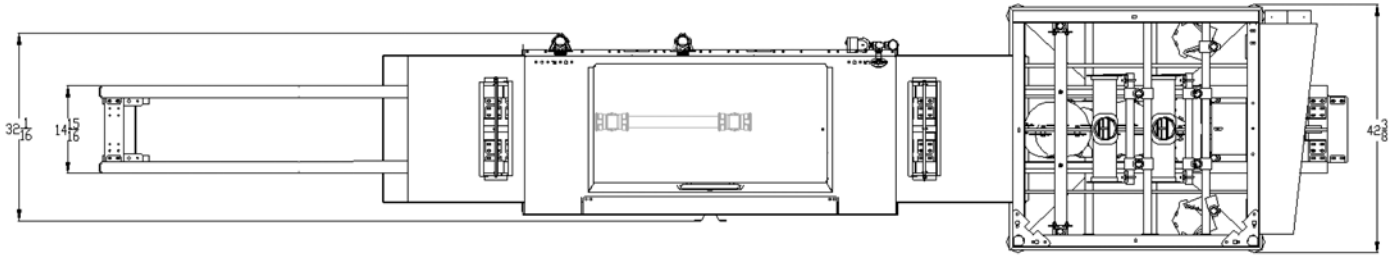

MAY BE DRAINED TO
EITHER END, PLUG
OPPOSITE SIDE

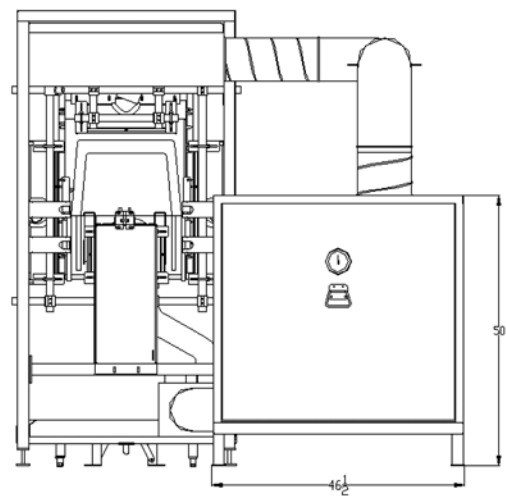
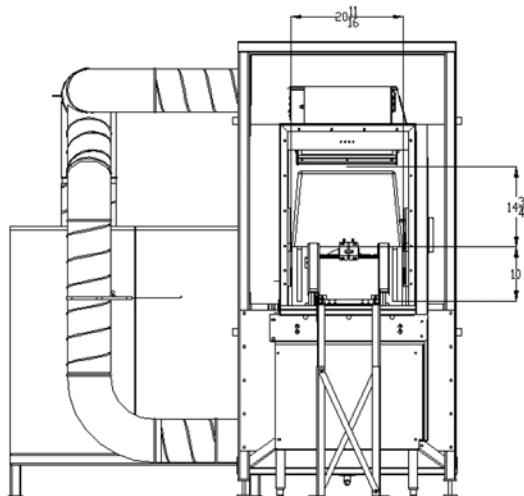



701 S Ridge Avenue, Troy, OH 45374
1-888-4HOBART • www.hobartcorp.com

CL64T INDUSTRIAL TOTE WASHER

SEPARATE SERVICE CONNECTION ELECTRIC HEAT 15 KW (WASH)			
VOLTAGE	RATED AMPS	MINIMUM SUPPLY CIRCUIT CONDUCTOR AMPACITY	MAXIMUM PROTECTIVE DEVICE
208/60/3	45	60	60
240/60/3	43	60	60
480/60/3	22	30	30

SEPARATE SERVICE CONNECTION ELECTRIC HEAT 10 KW (RINSE)			
VOLTAGE	RATED AMPS	MINIMUM SUPPLY CIRCUIT CONDUCTOR AMPACITY	MAXIMUM PROTECTIVE DEVICE
208/60/3	30	40	40
240/60/3	28.6	40	40
480/60/3	14.3	20	20

SEPARATE SERVICE CONNECTION FOR MOTORS ON ELECTRIC HEAT (1/6 HP CONVEYOR & 2 HP WASH)			
VOLTAGE	RATED AMPS	MINIMUM SUPPLY CIRCUIT CONDUCTOR AMPACITY	MAXIMUM PROTECTIVE DEVICE
208/60/3	15.6	20	20
240/60/3	15.1	20	20
480/60/3	9.1	15	15

BOOSTER HEAT 15 KW			
VOLTAGE	RATED AMPS	MINIMUM SUPPLY CIRCUIT CONDUCTOR AMPACITY	MAXIMUM PROTECTIVE DEVICE
208/60/3	45	60	60
240/60/3	40.1	50	50
480/60/3	20	25	25

BOOSTER HEAT 30 KW			
VOLTAGE	RATED AMPS	MINIMUM SUPPLY CIRCUIT CONDUCTOR AMPACITY	MAXIMUM PROTECTIVE DEVICE
208/60/3	83.9	90	60
240/60/3	80.2	90	50
480/60/3	40.1	50	25

SEPARATE SERVICE CONNECTION FOR MOTORS ON STEAM OR GAS HEAT (1/6 HP CONVEYOR & 2 HP WASH)			
VOLTAGE	RATED AMPS	MINIMUM SUPPLY CIRCUIT CONDUCTOR AMPACITY	MAXIMUM PROTECTIVE DEVICE
208/60/3	18.5	25	25
240/60/3	18.5	25	25
480/60/3	9.1	15	15

SEPARATE SERVICE CONNECTION HIGH PRESSURE BLOW-OFF			
VOLTAGE	RATED AMPS	MINIMUM SUPPLY CIRCUIT CONDUCTOR AMPACITY	MAXIMUM PROTECTIVE DEVICE
208/60/3	51	125	125
240/60/3	46	110	110
480/60/3	23	60	60



WARNING
ELECTRICAL AND GROUNDING CONNECTIONS MUST COMPLY WITH THE APPLICABLE PORTIONS OF THE NATIONAL ELECTRICAL CODE AND/OR OTHER LOCAL ELECTRICAL CODES.

CAUTION: CERTAIN MATERIALS INCLUDING SILVER, ALUMINUM, AND PEWTER ARE ATTACKED BY SODIUM HYPOCHLORITE (LIQUID BLEACH).

ATTN: PLUMBING CONNECTIONS MUST COMPLY WITH APPLICABLE SANITARY, SAFETY, AND PLUMBING CODES.

CL64T INDUSTRIAL TOTE WASHER

HOBART701 S Ridge Avenue, Troy, OH 45374
1-888-4HOBART • www.hobartcorp.com

DESIGN: Semi-automatic, high or low temperature double-tank, tote-type industrial washer with flexible thermal layer curtains at the ends of chamber and between wash, rinse and final rinse zones. Insulated hinged inspection doors located in front of machine provide easy access to wash arms, rinse arms, strainer, strainer basket, and pump intake screen. Length of machine inside tank is 64". Machine is designed to clean and sanitize with hot water 150°F wash, 160° power rinse and 180°F (minimum) final rinse, or low temperature 130°F wash and 120°F final rinse and a chemical sanitizer. Water hardness recommended to be 3 gr. for best results. Automatic interlocks shut off pump and conveyor if door is opened when machine is in operation.

CONSTRUCTION: Tank, chamber, frame, legs, control box, doors, and all panels are constructed of stainless steel.

PUMP: Two 165 gpm recirculating stainless steel pumps and impeller with a ceramic seat seal. Easily accessible pumps assembly permits quick inspection. The pumps are self-draining. All piping, distributing water to the upper and lower wash arms, is stainless steel tubing.

PUMP MOTOR: Built for Hobart, 2 hp grease-packed ball bearings, splash proof, ventilated with manual, resettable inherent overload protection. Available in electrical specifications of 208-240/60/3, and 480/60/3.

CONTROLS: A control module with power and "start/stop" buttons is mounted on top of the machine. Machine control circuitry is operated from a 120-volt control circuit transformer. Electrical components are completely wired with 105°C, 600V thermoplastic insulated wire with stranded conductors routed through UL listed electrical conduit or covered wire way.

CONVEYOR: This drive is designed for more even through-put of totes and allows for a 18.75-inch separation between the wash and the rinse zone. Totes conveyed automatically through wash and rinse zones and onto clean rails.

Ball Detent Clutch drive prevents damage to machine or totes, should movement of totes be obstructed. Tote tracks, conveyor structure, and drive units of stainless steel. Selectable conveyor speeds of: 4.0, 5.0, 6.0 FPM.

DRIVE MOTOR: Built for Hobart, 1/2 horsepower gear motor, ventilated with manual, resettable inherent overload protection. Available in electrical specification of 208-240/60/3, and 480/60/3.

POWER WASH AND RINSE: Wash and rinse tanks are equipped with upper and lower stainless steel CFD Wash Arms which effectively direct water jets to all tote surfaces. Both upper and lower wash arms are self-aligning and have easily removable end caps for cleaning without use of tools. A removable perforated stainless steel strainer pan supports a deep perforated stainless steel basket.

FINAL RINSE: Final rinse flow rate: 2.2 gpm, 132-gph. Stainless steel upper and lower Auto Position Rinse Arms™ have single rows of nozzles. Totes entering the rinse zone automatically trigger rinse. Final rinse water line is equipped with a vacuum breaker downstream of an electrically operated solenoid valve in common piping system. Removable perforated stainless steel strainer basket can be removed without

removing lower rinse arm. Rinse agent and Low Temp Final Rinse – Sanitizer agent (5.25% sodium hypochlorite – bleach) dispenser injection ports provided in final rinse piping above chamber. **Caution:** Certain materials, including silver, aluminum, and pewter are attacked by sodium hypochlorite (bleach) in the chemical sanitizing dishwasher mode of operation.

FILL: Fill water line is equipped with vacuum breaker on downstream side of electrically operated solenoid valve in common piping system, for automatic maintenance of tank level.

DRAIN AND OVERFLOW: Large bell-type automatic overflow and drain valve controlled from inside of machine. Drain automatically seats by closing inspection doors. Drain seal is large diameter, high temperature o-ring. Drain housing can be plumbed from load or unload end of machine.

STANDARD EQUIPMENT: Digital display of wash and final rinse temperature. Positive low water protection for tank heat. Thermal Layered Curtains throughout machine are keyed to ensure proper placement. Drain is automatically closed when inspection doors are closed. Stainless steel adjustable feet. Bolted stainless steel enclosure panels around perimeter and underneath machine. Automatic tank fill. Door interlock. Auto-timer. Vent fan and booster heater controls. Single point electrical connection. Low temperature alerts. Service diagnostics. Dirty water indicator. Delime notification. Conveyor dwell. Energy Saver Mode. NAFEM Data Protocol compliant.

TANK HEATING SELECTIONS (must choose one):

ELECTRIC: Two electric immersion heaters (15 KW and 10 KW). Tank water temperature is controlled by microprocessor controlled thermostat with positive low-water protection and magnetic contactor. (Disconnect switches not furnished.) A high limit device mounted on the surface of the tank additionally protects heating element.

STEAM: One-inch stainless steel steam coil. Tank water temperature controlled by microprocessor controlled thermostat with positive low-water protection. Steam supplied to machine through high temperature steam solenoid valve and line strainer.

GAS: Regulated infrared immersion tube gas burner system. Microprocessor controlled thermostat and a blower with a pressure switch control tank water temperature. Positive low water protection is provided. A high limit device mounted on the surface of the tube additionally protects immersion tube. A solid-state igniter board controls the gas valve and provides flame ignition. A transformer steps the control circuit voltage down from 120 volts to 24 volts to power the igniter board and gas valve. For natural gas, gas pressure to burner (customer connection) not to exceed 7" W.C. For LP gas, gas pressure to burner (customer connection) not to exceed 11" W.C. If gas pressure is higher than 7" W.C. natural or 11" W.C. LP pressure regulating valve must be supplied (by others) in the gas line to the dishwasher.

OPTIONAL EQUIPMENT AT EXTRA COST:

Stainless steel pressureless booster heater.
High pressure blow-off.
Table limit switch.
Drain water tempering kit.

As continued product improvement is a policy of Hobart, specifications are subject to change without notice.