

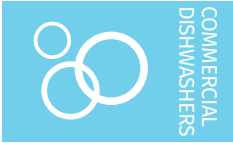

Project _____
 AIA # _____ SIS # _____
 Item # _____ Quantity _____ C.S.I. Section 114000



SL30 SIDE LOADING OPTION

For CLeN Series



SPECIFIER STATEMENT

The SL30 Side Loader option can be adapted to any Hobart non-CLCS Dishwasher. Model SL-30 adds 30" to length of machine.

MODELS

- SL30** Adds 30" to length of machine

STANDARD FEATURES

- + Automatically indexes rack at a 90° angle
- + Operates off the drive of the CLeN and requires no additional energy consumption
- + Easy to install
- + Stainless steel construction
- + Low maintenance
- + Easy to use
- + Saves valuable floor space
- + SL30 accepts full size sheet pans

Construction: Sump, back and end shields of formed 14-gauge stainless steel, heliarc-welded, with covered corners and all joints ground smooth and polished. Attached to dishmachine chamber with stainless steel bolts and reinforced with rigid stainless steel diagonal supports. Sump has 1/2" drain connection and perforated stainless steel strainer cover over drain opening.

Conveyor: Two stainless steel rack slides welded to cross member support. Drive member is single stainless steel pawl, connected to dishmachine conveyor by a stainless steel rod. Rack drive pawl operates on two rollers, supported by two stainless steel rods and is beveled to permit rack to slide easily into side-loading extension.

Shipping Weight: Ships separately weighing approximately 100 lbs. Field mount standard.

Note: Racks must have center and side index strips.

WARNING: Electrical and grounding connections must comply with the applicable portions of the National Electrical Code and/or other local electrical codes.

Plumbing connections must comply with applicable sanitary, safety and plumbing codes.

CLEN SERIES – SL30 SIDE LOADING OPTION

Approved by _____ Date _____ Approved by _____ Date _____



SL30 SIDE LOADING OPTION

For CleN Series

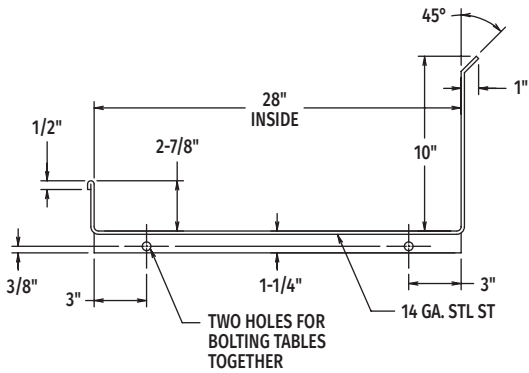

SECTION A-A
VIEW LOOKING TOWARD SL-30 TANK
THROUGH CUSTOMER'S TABLE

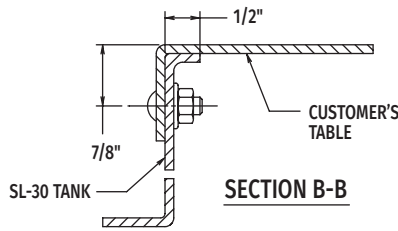

SECTION B-B

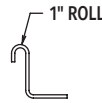

SECTION C-C

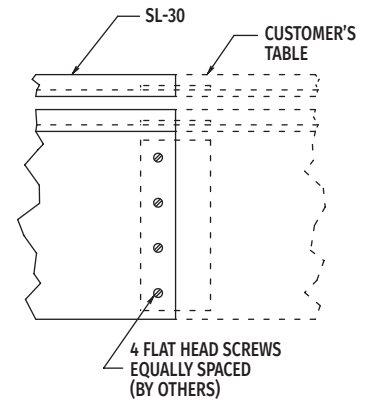

SECTION D-D

Note:

- All dimensions taken from floor line may be increased approximately 3/4" or decreased 1/2". For dimensions not shown, see specification sheet for model specified.

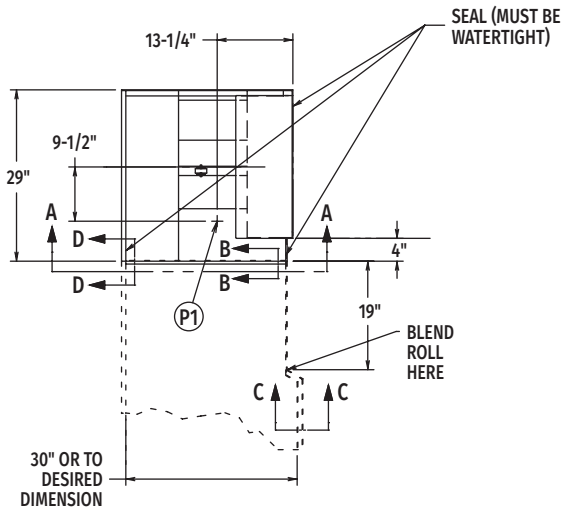

LEGEND

Plumbing Connection	
P1	Drain connection: 1-1/2" FPT.

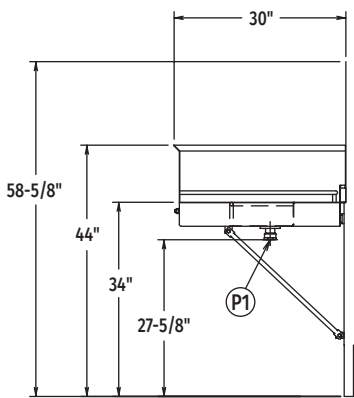

SL30 Side Loader
Left to Right Operation

MODEL:
CleN
30" SIDE LOADER
L-R OPERATION
D-936613
REV C

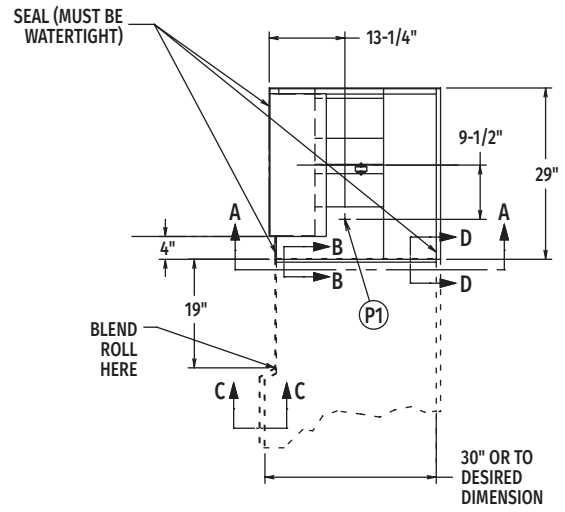

LEGEND

Plumbing Connection	
P1	Drain connection: 1-1/2" FPT.

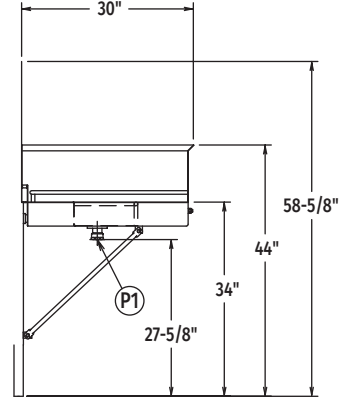

SL30 Side Loader
Right to Left Operation

MODEL:
CleN
30" SIDE LOADER
R-L OPERATION
D-936612
REV C

As continued product improvement is a policy of Hobart, specifications are subject to change without notice.

