



Project _____
 AIA # _____ SIS # _____
 Item # _____ Quantity _____ C.S.I. Section 114000



CL54eN-EGR GAS

High Temperature Rack Conveyor Dishwashing Machine

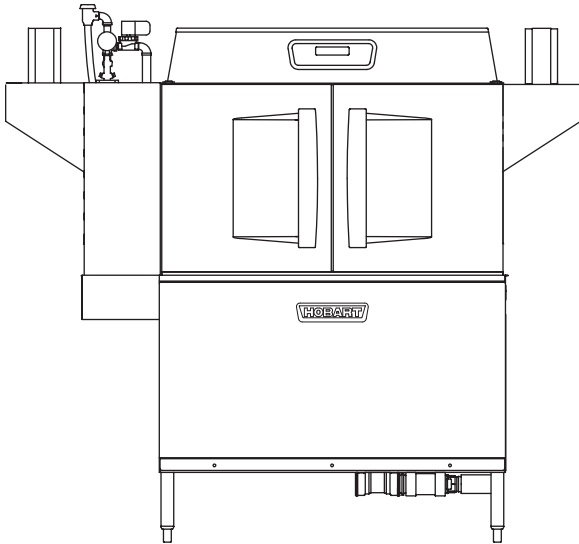

SPECIFIER STATEMENT

Specified dishwasher will be Hobart CL54eN Energy Recovery gas tank heat model with drain water energy recovery (DWER) and Opti-Rinse™. Includes 245 racks per hour capacity, insulated ergonomic cabinet style doors, dirty water indicator, configurable “intelligent” de-lime notification, top mounted computer controls, and NSF approved pot and pan cycle mode. The wash tank utilizes durable precision pressure sensor monitors in lieu of conventional mechanical floats. The 19.5" standard chamber height will accommodate up to (6) standard sheet pans at a time on an open-end sheet pan rack.

STANDARD FEATURES

- + 245 racks per hour
- + Drain water energy recovery (DWER)
- + Opti-Rinse™ system
- + Drain water tempering kit
- + Rapid return conveyor drive mechanism
- + Internal stainless steel pressure-less 30 KW booster heater
- + Large double door opening for ease of cleaning
- + Doors are insulated & hinged with door interlock switches
- + 19.5" chamber height opening (accepts sheet pans)
- + Top mounted micro-processor control module
- + Energy saver mode (programmable auto-shut down)
- + Dirty water indicator
- + Manager activated low temperature alert
- + NSF rated configurable pot and pan dwell mode
- + Configurable “intelligent” delime alert notification
- + Service diagnostics
- + Self-aligning wash manifolds
- + Stainless steel anti-clogging wash arms
- + Removable pump intake screen
- + Stainless steel self-draining pump and impeller
- + Single, sloping scrap screen and deep scrap basket
- + Stainless panels enclose perimeter and bottom
- + Door actuated drain closure
- + Vent fan control
- + Booster heater control
- + ENERGY STAR® Certified

OPTIONS & ACCESSORIES (Available at extra cost)

- Standard, short, and extended stainless steel vent hoods
- Direct drive unloader – adds 38" length. Reference spec F39520 for more details
- Side loader – SL23 adds 23" length, SL30 adds 30" length. Reference specs F40926 and F40927 for more details
- Blower-dryer – adds 33¼" to length. Reference spec F40252 for more details (ships separate from dishmachine, contact Hobart Service for installation)
- Flanged feet kit (requires two kits)
- Higher than standard chamber (24" opening)
- Table limit switch with 10' wire
- Correctional package (contact Hobart for details)
- Pressure regulator valve (PRV), for use with external booster
- Water shock absorber kit
- Factory-mounted circuit breakers (contact Hobart for details)
- Common electrical connection (see page 4)

CLEAN SERIES – CL54eN-EGR GAS

Approved by _____ Date _____ Approved by _____ Date _____



CL54eN-EGR GAS

High Temperature Rack Conveyor

Dishwashing Machine

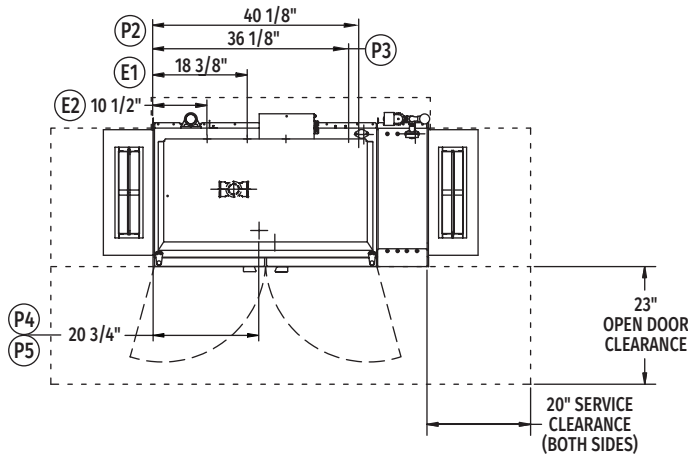

Top View Left to Right

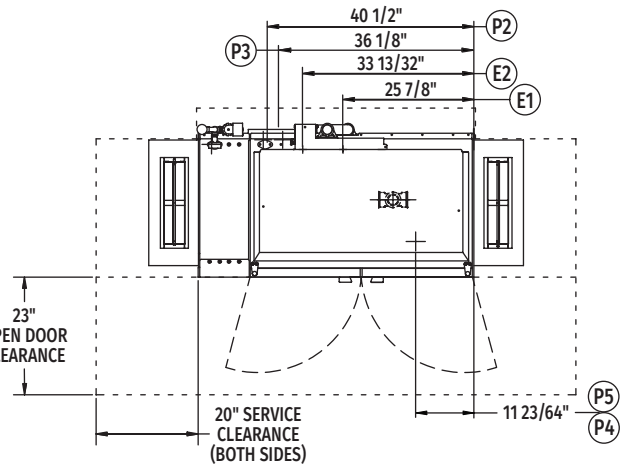

Top View Right to Left

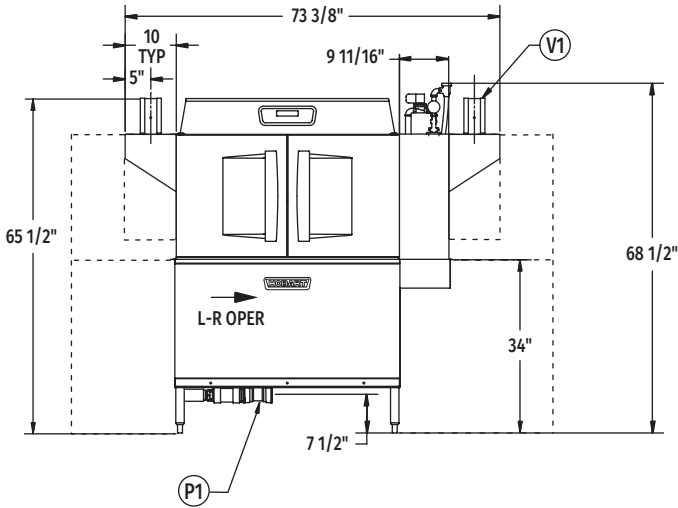

Front View Left to Right

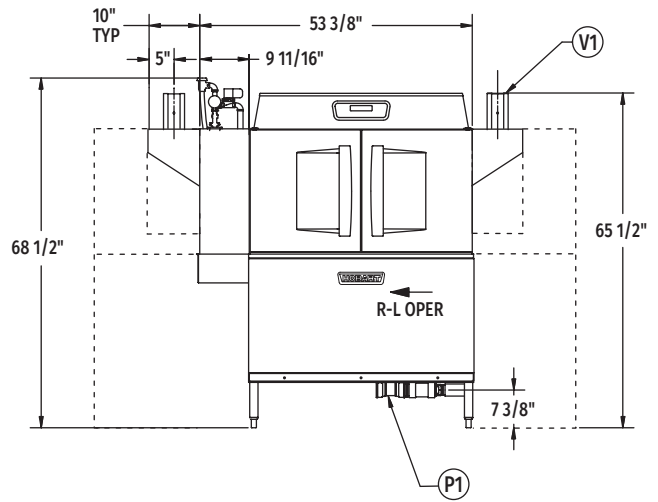

Front View Right to Left

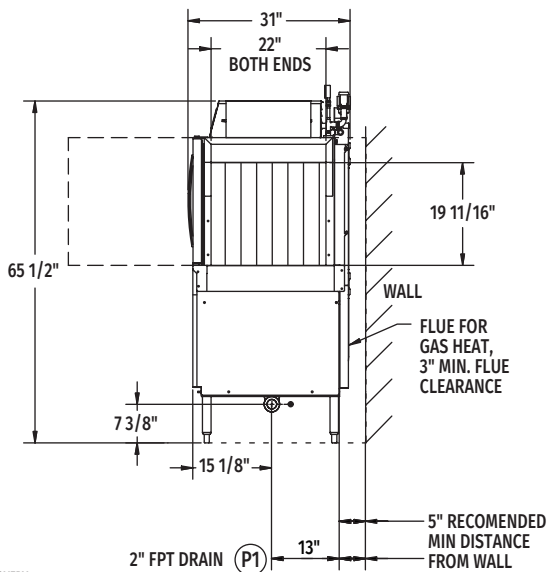

Side View

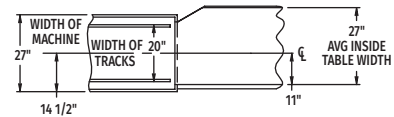

Suggested Track and Table Layout

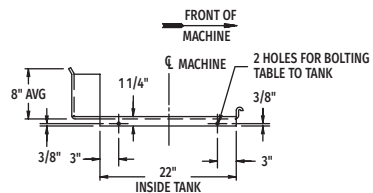

View Showing Hole Locations in Turned Down Portion of Table

MODEL: CL54eN ENERGY RECOVERY
L-R OPERATION
D-974803
REV B

MODEL: CL54eN ENERGY RECOVERY
R-L OPERATION
D-974802
REV B



CL54eN-EGR GAS

High Temperature Rack Conveyor Dishwashing Machine

LEGEND

Electrical Connections	
E1	Motors and controls 1-1/4" or 2" conduit, 63-3/4" AFF.
E2	Internal electric booster 1-1/4" or 2" conduit, 63-3/4" AFF.
NOTE: Common electrical connection (single point) available, see page 4 for details.	
Plumbing Connections	
P1	Drain. May be drained to either side of valve, plug opposite side 2" FPT. Recommend a floor drain minimum of 12" from machine for access and maintenance. 7-3/8" AFF.
P2	Hot water. 1/2" FPT connection. 1/2", 11-3/16" AFF. See plumbing notes for required temperatures.
P3	Cold water connection 1/2" FPT, cold water temperature 80°F, maximum 7-3/8" AFF.
Gas Connections (Natural Gas P4 or L.P. P5)	
P4	Gas connection – natural, 1/2" FPT, 10-3/4" AFF; 3.5" minimum, 7" maximum W.C. incoming.
P5	Gas connection – L.P., 1/2" FPT, 10-3/4" AFF; 8" minimum, 11" maximum W.C. incoming.
Vent Connections	
V1	Optional vent hoods, 4" x 16" vent stack with damper.

WARNING: Plumbing and electrical connections should be made by qualified personnel who will observe all the applicable plumbing, sanitary, safety codes and National Electrical Code.

WARNING: Gas heat machines must be provided with a means to exhaust the flue gases to the exterior of the building.

Plumbing Notes: Minimum incoming water temperatures: 110°F for 30kW internal booster. Building flowing water pressure to dish machine is 20 PSI (+/- 5 PSI).

Single cold water connection supplies both drain water energy recovery and drain water tempering.

If gas pressure is higher than 7" (Natural) or 11" (LP) W.C., a pressure regulating valve must be installed (by others) in the gas line to the dish machine.

SPECIFICATIONS

Capacities

Racks per Hour (NSF rated)	245
Wash Tank (U.S. gallons)	23
Conveyor Speed (feet per minute)	6.8

Motor Horsepower

Drive	1/6
Wash2

Water Consumption

U.S. Gallons per Hour (maximum use at 20 PSI)	136
U.S. Gallons per Rack	0.56
Peak Drain Flow (U.S. gallons per minute)	38

Heating

Tank Heat, LP or Natural Gas (BTU per hour)	78,000
Electric Booster (built-in) (kW for 70°F rise)	30

Venting

Load End (minimum CFM)	200
Unload End (minimum CFM)	400
(Gas exhaust venting must be installed according to local code)	

Shipping Weight (approximate)654 lbs.

Crated Dimensions.63"L x 38"W x 78"H

E1	Electrical Connection (3 PH only) Motors and Controls			
	Voltage	Rated Amps	Minimum Supply Circuit Ampacity	Maximum Protective Device
	208/60/3	10.7	15	15
	240/60/3	10.7	15	15
	480/60/3	6.7	15	15
	600/60/3	6.1	15	15

E2	Booster Heat 30 kW Minimum 110°F Incoming Water			
	Voltage	Rated Amps	Minimum Supply Circuit Ampacity	Maximum Protective Device
	208/60/3	83.9	90	90
	240/60/3	80.2	90	90
	480/60/3	40.1	50	50
	600/60/3	33.7	40	40

CL54eN-EGR Gas Heat Dissipation	
BTU/HR.	
Latent	Sensible
49,100	21,000



CL54eN-EGR GAS

High Temperature Rack Conveyor Dishwashing Machine

COMMON ELECTRICAL CONNECTION (SINGLE POINT) – CONTACT FACTORY FOR ADDITIONAL INFORMATION

Common Electrical Connection (Includes Motors & Controls and Electric Booster Heater)			
Voltage	MACHINE AND 30kW BOOSTER		
	Rated Amps	Minimum Supply Circuit Ampacity	Maximum Protective Device
208/60/3	94.6	110	110
240/60/3	94.6	110	110
480/60/3	46.8	60	60
600/60/3	39.8	55	55

VENT HOOD OPTIONS (Adjustable, vent stack can be adjusted 1" to either side)

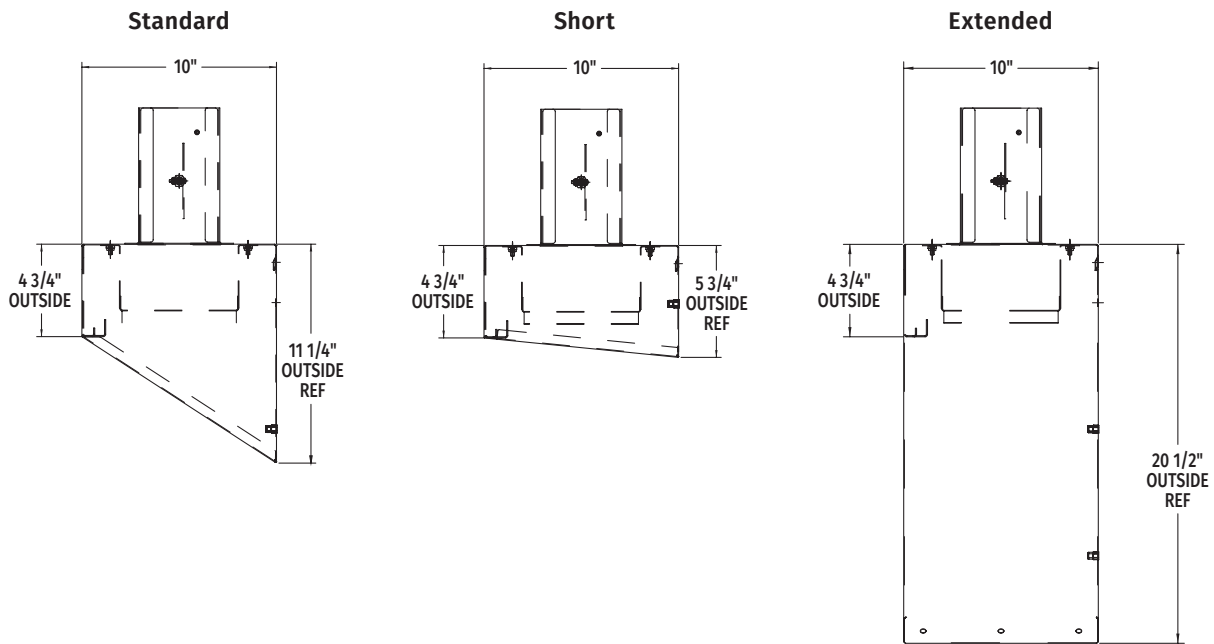

As continued product improvement is a policy of Hobart, specifications are subject to change without notice.