

HMM30-1STD
Mixer



SPECIFIER STATEMENT

The specified unit shall provide a minimum of 1 HP output at the planetary shaft and feature a gear-driven transmission. The mixer shall include three fixed speed selections with agitator RPMs of 94, 173, and 318. Standard features shall include digital controls with sealed push buttons, an ergonomic bowl lift, GearSafe Max™ technology, and Last Time Remind functionality. The unit shall be supplied with a stainless-steel bowl, wire whip, cast aluminum flat beater, cast aluminum dough hook, and a removable bowl guard.

Project _____
AIA # _____ SIS # _____
Item # _____ Quantity _____ C.S.I. Section 114000

MODEL

- HMM30-1STD** 30-quart mixer

STANDARD FEATURES

- + Gear transmission
- + Three fixed speeds
- + Beater, whip and dough hook
- + Heavy-duty motor
- + 1 H.P. planetary output
- + GearSafe Max™ technology
- + Digital timer with Last Time Remind
- + SmartFinish™ Alert
- + Large, easy-to-use controls
- + Stainless steel removable bowl guard
- + Two-tone finish
- + #12 taper attachment hub

ACCESSORY PACKAGE

- HMM30-1STD Standard accessory package (includes):
 - 30-quart stainless steel bowl
 - 30-quart beater
 - 30-quart whip
 - 30-quart dough hook

HMM30-1STD MIXER

Approved by _____ Date _____ Approved by _____ Date _____

SOLUTIONS/BENEFITS

HEAVY-DUTY PERFORMANCE 

1 HP High Torque Heavy-Duty Motor

Gear Transmission

- + Reliable speed control
- + Consistent torque under load

Three Fixed Speeds

- + Optimized for uniform ingredient incorporation and reliable mixing performance

EASE OF USE 

Digital Timer

- + Set minutes and seconds for accurate mixing performance
- + Intuitive time setting and clear monitoring throughout the mix cycle
- + SmartFinish Alert features a five-second audible countdown to signal cycle completion

Last Time Remind

- + Remembers the last time set
- + Consistent timing delivers uniform product quality, batch after batch

Ergonomic Bowl lift with EZ Grip Handle

- + Smoothly moves the bowl into mixing position

Bayonet Style Agitators

- + Beater, whip and dough hook included

SANITATION & CLEANING 

Stainless Steel Bowl Guard

- + Removes for easy cleaning

OPERATOR ASSURANCE 

GearSafe Max Technology

- + Gear protection for easy speed changes during operation

Triple Interlock System

- + Bowl-in-place
- + Bowl-up position
- + Bowl guard

HMM30 MIXER CAPACITY CHART

Recommended Maximum Capacities – dough capacities based on 70°F. water and 12% flour moisture.

Product	Agitators Suitable for Operation	HMM30
CAPACITY OF BOWL (QUARTS LIQUID)		30
Egg Whites	whip	1.5 qts.
Mashed Potatoes	beater	23 lbs.
Mayonnaise (quarts of oil)	beater or dough	16 qt.
Meringue (quarts of water)	whip	2 qt.
Waffle or Hot Cake Batter	beater	12 qts.
Whipped Cream	whip	6 qts.
Cake	beater	30 lbs.
Cookies, Sugar	beater	23 lbs.
Dough Pie	beater	24 lbs.
Dough, Bread or Roll (Light-Medium) 60% AR §	dough	40 lbs.
Dough, Heavy Bread 55% AR §	dough	30 lbs.□
Dough, Thin Pizza 40% AR (maximum mix time 5 minutes) §‡	dough	14 lbs.□
Dough, Medium Pizza 50% AR §‡	dough	20 lbs.□
Dough, Thick Pizza 60% AR §	dough	40 lbs.□
Dough, Raised Donut 65% AR	dough	15 lbs.□
Dough, Whole Wheat 70% AR	dough	40 lbs.
Fondant Icing	beater	18 lbs.
Eggs & Sugar for Sponge Cake	beater	12 lbs.
Shortening & Sugar, Creamed	beater	24 lbs.
Pasta, Basic Egg Noodle (maximum mix time 5 minutes)	dough	8 lbs.□

NOTE: % AR (% Absorption Ratio) - Water weight divided by flour weight. Capacity depends on moisture content of dough.

□ 1st Speed

* 2nd Speed

† 3rd Speed

§ If high gluten flour is used, reduce above dough batch size by 10%.

‡ 2nd Speed should never be used on 50% AR or lower products.

USE OF ICE REQUIRES A 10% REDUCTION IN BATCH SIZE.

1 gallon of water weighs 8.33 lbs.

NOTE: Attachment hub should not be used while mixing.

SPECIFICATIONS

Motor: 1 HP high torque heavy-duty motor
120/60/1 10.0 Amps

Electrical: 120/60/1 – ETL Listed.

GFCI: Compatible with the following
Legrand 1595
Legrand 1597
Legrand 2097
Eaton TRSGF15W

Controls: Solid state overload protection. Internally sealed push buttons. No Volt Release. Standard digital timer. **Last Time Remind**, recalls the time set from last batch operation.

Transmission: Gear-driven. Gears are constant mesh heat-treated hardened alloy steel along with anti-friction ball bearings. Grease lubricants furnished to all gears and shafts.

Speeds:

	Agitator (RPM)	Attachment (RPM)
First	94	54
Second	173	100
Third	318	183

Bowl Guard: Stainless steel wire front and solid rear portion. Front portion of guard rotates easily to add ingredients and install or remove agitator. It detaches in seconds for cleaning in dishwasher or sink. Rear portion of guard can be quickly cleaned in position. Guard must be in closed position before mixer will operate.

Bowl Lift: Ergonomic lift-into-place design for smooth, easy operation.

Finish: Duo-tone gray & black.

Attachment Hub: Comes with front-mounted Hobart standard #12 taper attachment hub for use with Hobart #12 size attachments.

Attachments & Accessories (Available at extra cost):

- BOWL-HMM30 – Stainless steel bowl
- BEATER-HMM30 – Flat beater
- WHIP-HMM30 – Wire whip
- DOUGH-HMM30 – Dough hook
- VS9 Vegetable slicer
- Meat chopper attachment

Machine Voltages	
Service Current Requirement if Plug Connected	120/60/1
	15 Amp.
Terminal Designation of Plug	2 Pole 3 Wire Grounding
NEMA Plug Configuration	5-15P
Plug Configuration	
Molded Plug on Cord	Yes
Plug - Straight/Angle	Straight
NEMA Receptacle or Connector Configuration	5-15R

SPECIFICATIONS

Electrical Specifications: 120/60/1 – ETL listed

Weight: 313 lbs. net; 416 lbs. domestic shipping.

Warranty: Unit has full one-year warranty on parts, labor and mileage against manufacturer's defects. Service contracts are available

DETAILS AND DIMENSIONS

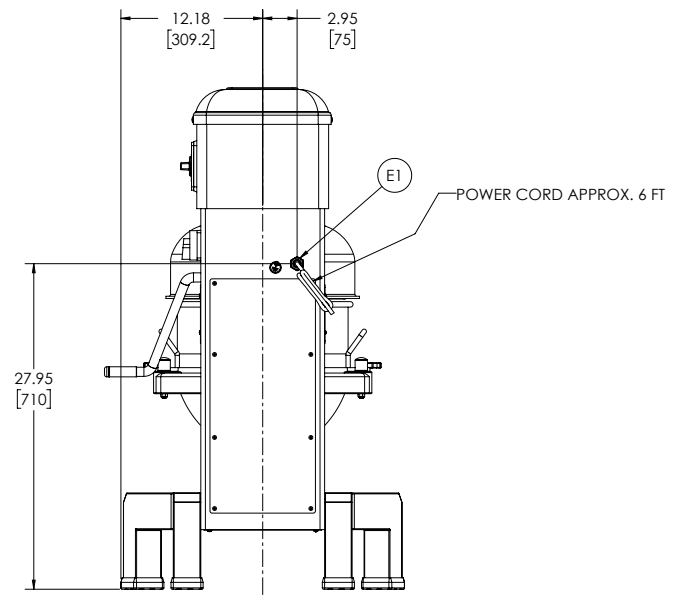
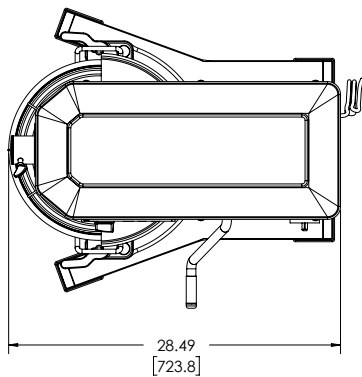
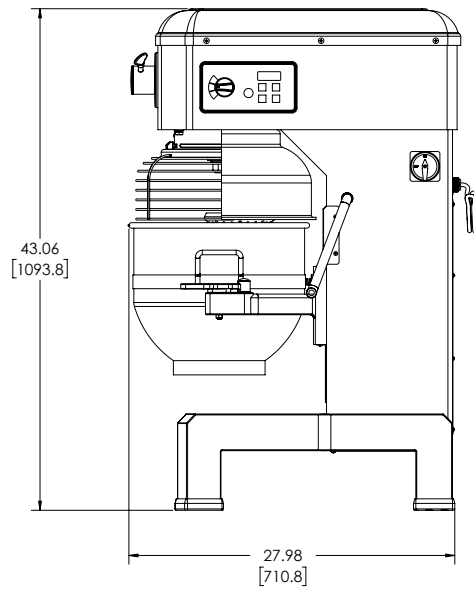
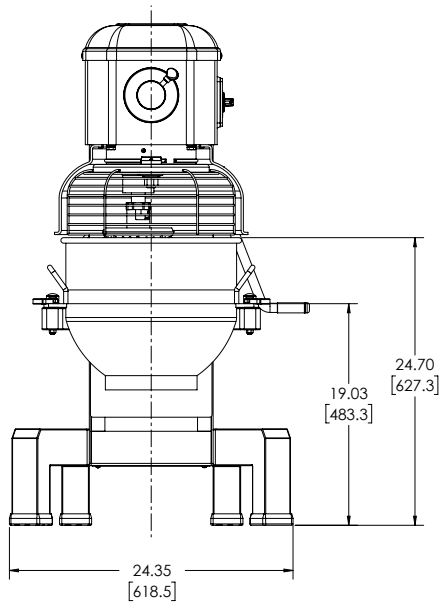

WARNING: Must comply with the applicable portions of the National Electrical Code and/or other local electrical codes.