



UHT SERIES

2-SECTION SOLID DOOR COMPACT REFRIGERATED UNDERCOUNTER



Project Name:	Location:	AIA #:	
Item #:	Qty:	Model #:	SIS #:

UHT SERIES - STAINLESS STEEL EXTERIOR & INTERIOR



48" WIDE MODELS

- UHT48-LR Hinged Left/Right
- UHT48-LL Hinged Left/Left
- UHT48-RR Hinged Right/Right

SPECIFICATIONS

DIMENSIONAL DATA	
Capacity cu. ft.	13.56 (383 cu l)
Length in.	48 (121.9 cm)
Depth in.	32 (81.3 cm)
Overall Height in. ²	33-5/8 (85.4 cm)
ELECTRICAL DATA	
Horsepower ¹	1/5
Amps	7.2
Voltage	115/60/1
NEMA	5-15P
REFRIGERATION DATA	
Refrigerant	R-290
Charge Amount oz.	5 (142 g)
BTU	1680

When ordering please specify:
Voltage, Hinging, and Options



NEMA 5-15P

1. Based on 90°F ambient & 20°F evaporator.
2. Overall height includes 4" (10.2 cm) for casters.

PLAN VIEW

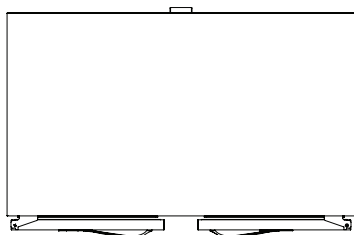

TOP VIEW

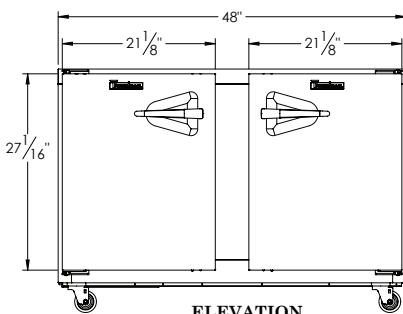
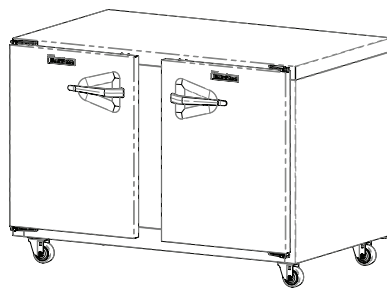

ELEVATION

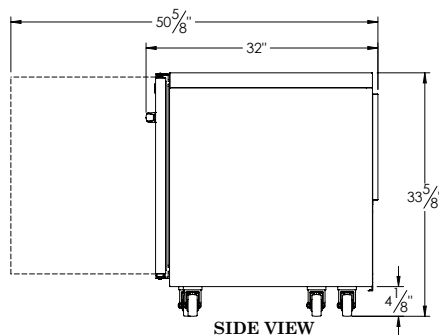

SIDE VIEW



Models listed to applicable UL, CSA, and NSF standards by an approved NRTL. Consult the factory or unit data plate for additional information.

Specifications subject to change without notice. Chart dimensions are rounded up to the nearest 1/16" (centimeters rounded up to the nearest tenth).



UHT SERIES

2-SECTION SOLID DOOR COMPACT REFRIGERATED UNDERCOUNTER



Project Name:	Location:	AIA #:	
Item #:	Qty:	Model #:	SIS #:

REFRIGERATION SYSTEM

- Self-contained, rear-mounted system uses environmentally friendly, minimal GWP R-290 refrigerant
- Front-breathing system allows zero-clearance installation
- High performance, balanced system operates at 34-38°F (11-3.3°C) to maintain consistent, food-safe temperatures
- Specialized, clock-wise airflow design
- LED display for electronic control is water-resistant
- Capillary tube refrigerant metering
- Forced-air evaporator coil; non-electric condensate evaporator

CABINET CONSTRUCTION

- Stainless steel exterior and interior
- Exterior back and bottom are constructed of heavy gauge galvanized steel
- Cabinet and doors are insulated with an average of 2" (5.1 cm) thick high density, non-CFC foamed-in-place polyurethane
- A set of (4) 4" (10.2 cm) high casters; all with brakes
- 9' (2.7 m) cord & plug provided

DOORS

- Doors are self-closing with a stay-open feature
- Doors are field reversible; requires new door
- Magnetic, snap-in EZ-Clean™ door gaskets are chemical-resistant

FACTORY-INSTALLED INTERIORS

- (2) adjustable, factory-installed coated wire shelves per section supported on pilasters

FIELD-INSTALLED INTERIOR/SUPPORT OPTIONS

- Additional coated wire shelves (SHELF48 UPPER or LOWER)
- Heavy-gauge stainless steel top with 4" (10.2 cm) backsplash (CU48TOP-BSW0)
- Set of (4) 2-3/4" (6.9 cm) casters (CK26)
- Set of (4) 3-1/2" (8.9 cm) casters (CK24)
- Set of (4) 6" (15.2 cm) casters (CK20)
- Set of (4) 6" (15.2 cm) legs (LK4)

FACTORY-INSTALLED OPTIONS

- Stainless steel finished back (model number suffix -SB)

WARRANTY

Both a six-year parts and labor warranty, and an additional one-year compressor parts warranty (for a total of seven years) are provided standard.

CAD and/or Revit Files Available

<https://traulsen.klccad.com>

Approved by:	Approved by:	Date:
--------------	--------------	-------