

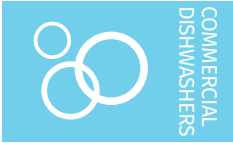

Project _____
 AIA # _____ SIS # _____
 Item # _____ Quantity _____ C.S.I. Section 114000



CLCS66eN-EGR STEAM

High Temperature Corner Scrapper Rack Conveyor Dishwashing Machine

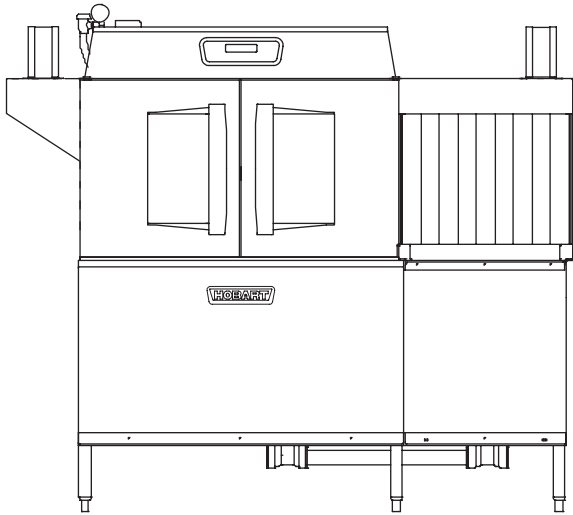

STANDARD FEATURES

- + 202 racks per hour
- + 22" power scrapper
- + Drain water energy recovery (DWER)
- + Opti-Rinse™ system
- + Drain water tempering kit
- + Rapid return conveyor drive mechanism
- + Internal stainless steel pressure-less 30 KW booster heater
- + Large double door opening for ease of cleaning
- + Doors are insulated & hinged with door interlock switches
- + 19.5" chamber height opening (accepts sheet pans)
- + Top mounted micro-processor control module
- + Energy saver mode (programmable auto-shut down)
- + Dirty water indicator
- + Manager activated low temperature alert
- + NSF rated configurable pot and pan dwell mode
- + Configurable "intelligent" delime notification
- + Service diagnostics
- + Self-aligning wash manifolds
- + Stainless steel anti-clogging wash arms
- + Removable pump intake screen
- + Stainless steel self-draining pump and impeller
- + Single, sloping scrap screen and deep scrap basket
- + Stainless panels enclose perimeter and bottom
- + Door actuated drain closure
- + Vent fan control
- + Booster heater control
- + ENERGY STAR® Certified

CLEAN SERIES – CLCS66eN-EGR STEAM



SPECIFIER STATEMENT

Specified dishwasher will be Hobart CLCS66eN Energy Recovery steam tank heat model with corner scrapper, drain water energy recovery (DWER) and Opti-Rinse™. Includes 22" power scrapper, insulated ergonomic cabinet style doors, dirty water indicator, configurable "intelligent" de-lime notification, top mounted computer controls, and NSF approved pot and pan cycle mode. The wash tank utilizes durable precision pressure sensor monitors in lieu of conventional mechanical floats.

OPTIONS & ACCESSORIES (Available at extra cost)

- Standard, short, and extended stainless steel vent hoods
- Direct drive unloader – adds 38" length. Reference spec F39520 for more details
- Side loader – SL23 adds 23" length, SL30 adds 30" length. Reference specs F40926 and F40927 for more details
- Blower-dryer – adds 33 1/8" to length. Reference spec F40252 for more details (ships separate from dishmachine, contact Hobart Service for installation)
- Flanged feet kit (requires two kits)
- Higher than standard chamber (24" opening)
- Table limit switch with 10' wire
- Correctional package (contact Hobart for details)
- Pressure regulator valve (PRV), for use with external booster
- Water shock absorber kit
- Factory-mounted circuit breakers (contact Hobart for details)
- Common electrical connection (see page 4)

Approved by _____ Date _____ Approved by _____ Date _____



CLCS66eN-EGR STEAM

High Temperature Corner Scrapper Rack Conveyor Dishwashing Machine

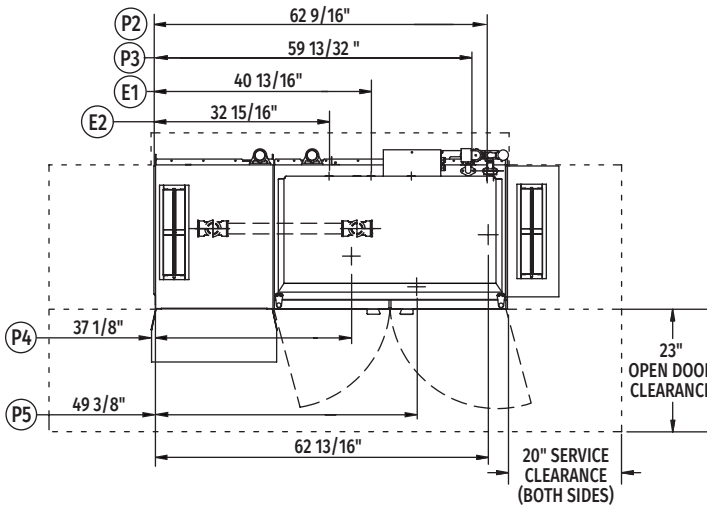

Top View Left to Right

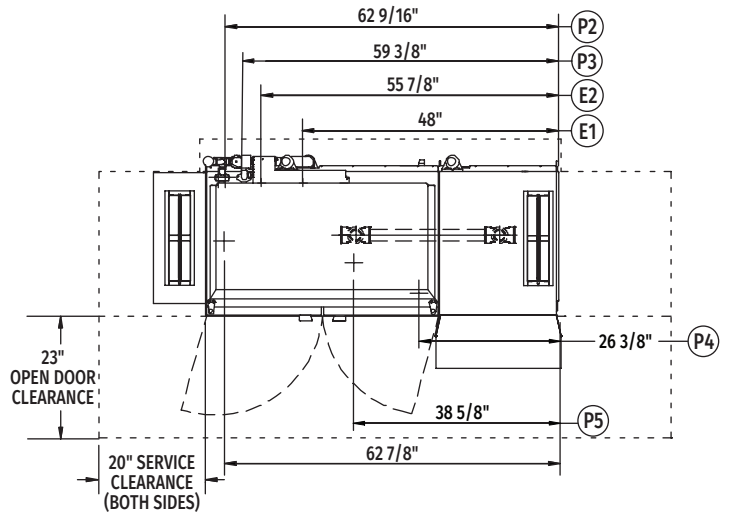

Top View Right to Left

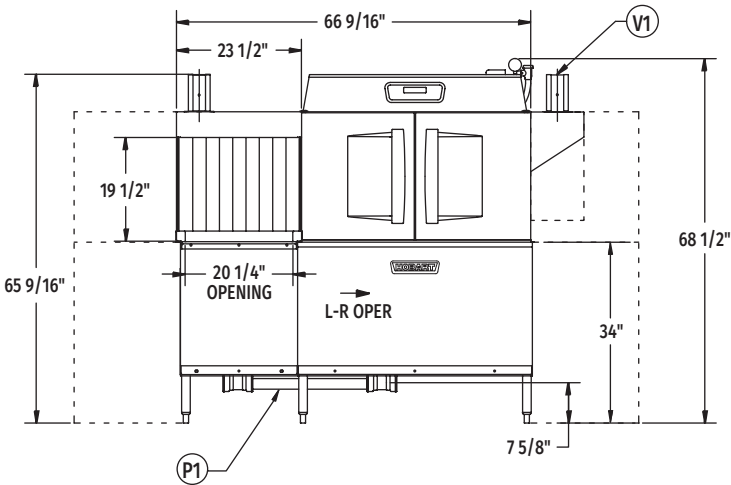

Front View Left to Right

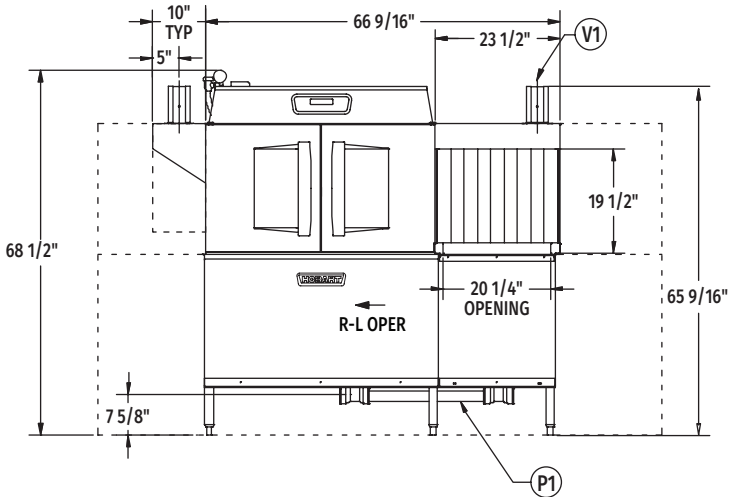

Front View Right to Left

VENT HOOD OPTIONS

(Adjustable, vent stack can be adjusted 1" to either side)

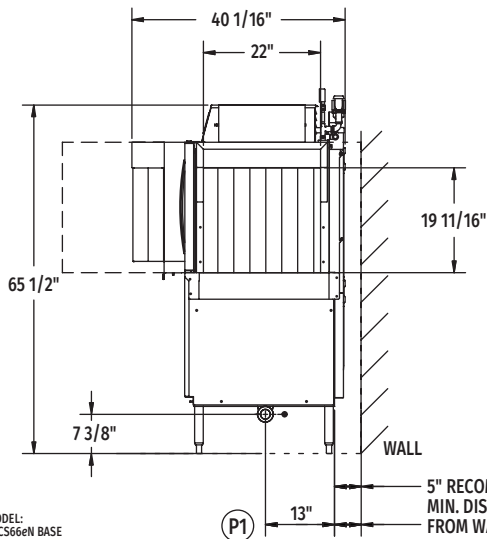
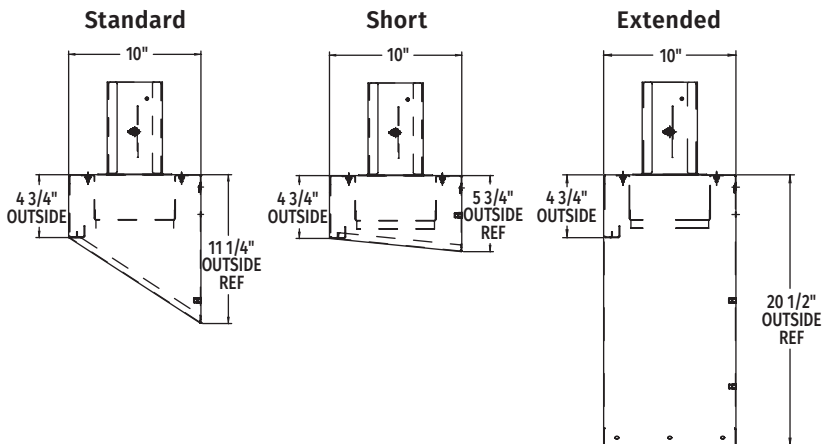

Side View

Reference page 4
for installation drawings

MODEL: CLCS66eN BASE
L-R OPERATION
D-974813
REV B

MODEL: CLCS66eN BASE
R-L OPERATION
D-974812
REV B



CLCS66eN-EGR STEAM

High Temperature Corner Scrapper Rack Conveyor Dishwashing Machine

LEGEND

Electrical Connections	
E1	Motors and controls 1-1/4" or 2" conduit, 63-3/4" AFF.
E2	Internal electric booster (in lieu of external steam booster) 1-1/4" or 2" conduit, 63-3/4" AFF.
NOTE: Common electrical connection (single point) available, see page 4 for details. Booster information, see page 4.	
Plumbing Connections	
P1	Drain. May be drained to either side of valve, plug opposite side 2" FPT. Recommend a floor drain minimum of 12" from machine for access and maintenance. 7-3/8" AFF.
P2	Hot water. 1/2" FPT connection. 1/2", 11-3/16" AFF. See plumbing notes for required temperatures.
P3	Cold water connection 1/2" FPT, cold water temperature 80°F, maximum 7-3/8" AFF.
Steam Connections (P4 or P5)	
P4	Steam coils: 10 to 50 PSI flowing, 3/4" FPT, 11-18" AFF.
P5	Condensate return: A 10 PSI minimum differential pressure across the steam trap must be maintained. 3/4" FPT, 11-1/8" AFF one connection. (One bucket type trap furnished).
Vent Connections	
V1	Optional vent hoods, 4" x 16" vent stack with damper.

E1	Electrical Connection (3 PH only) Motors and Controls		
Voltage	Rated Amps	Minimum Supply Circuit Ampacity	Maximum Protective Device
208/60/3	16.6	20	20
240/60/3	16.6	20	20
480/60/3	9.4	15	15
600/60/3	8.4	15	15

E2	Booster Heat 30 kW Minimum 110°F Incoming Water		
Voltage	Rated Amps	Minimum Supply Circuit Ampacity	Maximum Protective Device
208/60/3	83.9	90	90
240/60/3	80.2	90	90
480/60/3	40.1	50	50
600/60/3	33.7	40	40

SPECIFICATIONS

Capacities

Racks per Hour (NSF rated)	202
Wash Tank (U.S. gallons)	23
Power Scrapper (U.S. gallons)	23
Conveyor Speed (feet per minute)	5.6

Motor Horsepower

Drive	1/6
Wash2
Power Scrapper2

Water Consumption

U.S. Gallons per Hour (maximum use at 20 PSI)	126
U.S. Gallons per Rack	0.62
Peak Drain Flow (U.S. gallons per minute)	38

Heating

Tank Heat, steam coils (pounds per hour)	65
Electric Booster (built-in) (kW for 70°F rise)	30
Steam Booster (external) (pounds per hour)	60
(If used on 20 PSI steam, 20 PSI water flowing, 130°F entering water raised to 180°F minimum)	

Venting

Load End (minimum CFM)	200
Unload End (minimum CFM)	400

Shipping Weight (approximate)895 lbs.

Crated Dimensions.76"L x 38"W x 78"H

CLPS66eN-EGR Steam Heat Dissipation	
BTU/HR.	
Latent	Sensible
46,200	19,800

WARNING: Plumbing and electrical connections should be made by qualified personnel who will observe all the applicable plumbing, sanitary, safety codes and National Electrical Code.

Plumbing Notes: Minimum incoming water temperatures: 110°F for 30kW internal booster. Building flowing water pressure to dish machine is 20 PSI (+/- 5 PSI).

Single cold water connection supplies both drain water energy recovery and drain water tempering.

Steam Heat Only: Flowing steam pressures above 50 PSI must have a pressure regulator (by others) installed in the steam line.

Shut off valve must be supplied (by others) in the steam line to the dish machine.

