



Project _____
 AIA # _____ SIS # _____
 Item # _____ Quantity _____ C.S.I. Section 114000



AMTL TWO LEVEL ELECTRIC

High Temperature Door-Style Dishwashing Machine



PENDING APPROVALS:



SPECIFIER STATEMENT

Specified unit will be a Hobart AMTL electric high temperature two-level dishwashing machine. Features include two wash chambers with separate pumped rinse systems, pillarless 5-sided insulated hood, touchscreen controls with WiFi connectivity, NSF pot and pan rating for 2-, 4- & 6-minute cycles (upper chamber), Extended/utensil wash cycles (lower chamber), 17" door opening (upper chamber), 8 $\frac{3}{8}$ " door opening (lower chamber), pumped drain, auto door start with auto fill & AutoClean, interchangeable stainless steel wash and rinse arms (upper chamber), snap-in rinse arm (lower chamber), delime notification and cycle, advanced diagnostics and service connection, up to 80 racks per hour, .62 U.S. gallons per rack (upper chamber), .62 U.S. gallons per rack (lower chamber).

1 year parts and labor warranty.

STANDARD FEATURES

- + Independent wash chambers with separate pumped rinse systems
- + **Upper Chamber:** .62 gallons per rack pumped final rinse
- + **Lower Chamber:** .62 gallons per rack pumped final rinse
- + 80 racks per hour – hot water sanitizing
- + Multiple cycle operations including a utensil cycle on the lower chamber
- + 17" upper chamber door opening
- + 8 $\frac{3}{8}$ " lower chamber door opening will accept 7" plates
- + User-friendly smart touchscreen controls
- + WiFi connectivity and Hobart Smart Connect app
- + Two stage filtration
- + Pillarless opening
- + 5-sided insulated hood
- + Lower insulated door
- + Single point electrical connection standard, field convertible to dual point connection
- + 3 phase standard, field convertible to single phase
- + Temperature lockouts
- + Pumped drain
- + Timed wash cycles for 1, 2, 4 or 6 minutes (lower chamber – utensil cycle for 3 and 6 minutes)
- + **Upper Chamber:** NSF pot and pan rating for 2-, 4- & 6- minute cycles
- + Sense-A-Temp™ 60° F rise electric booster heater
- + Self-draining, high efficiency wash pump with stainless steel impeller
- + Stainless steel drawn tank, tank shelf, chamber, trim panels, frame and feet
- + Spring counterbalanced chamber with thermo-plastic rollers
- + **Upper Chamber:** Revolving, interchangeable upper and lower anti-clogging wash arms
- + **Upper Chamber:** Revolving, interchangeable upper and lower rinse arms
- + **Lower Chamber:** Snap-in revolving lower wash and rinse arm
- + Slanted, self-locating, one-piece scrap screen and basket system
- + 120°F incoming water required
- + Automatic fill
- + Door actuated start
- + AutoClean
- + Vent fan control
- + Factory startup
- + USB connection for service diagnostics
- + Straight-through installation only
- + Delime cycle with notification (field activated)

OPTIONS & ACCESSORIES (Available at extra cost)

- Peg Rack
- Combination rack
- Drain water tempering kit
- Water softener
- Flanged and seismic feet
- End of cycle audible alarm (field activated)
- Water hammer arrestor kit
- Fold down table

AMTL SERIES – AMTL TWO LEVEL ELECTRIC

Approved by _____ Date _____ Approved by _____ Date _____



AMTL TWO LEVEL ELECTRIC

High Temperature
Door-Style Dishwashing Machine

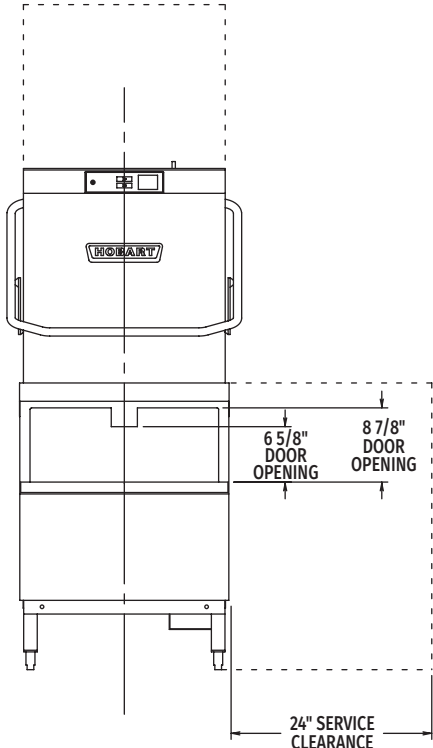

Front View

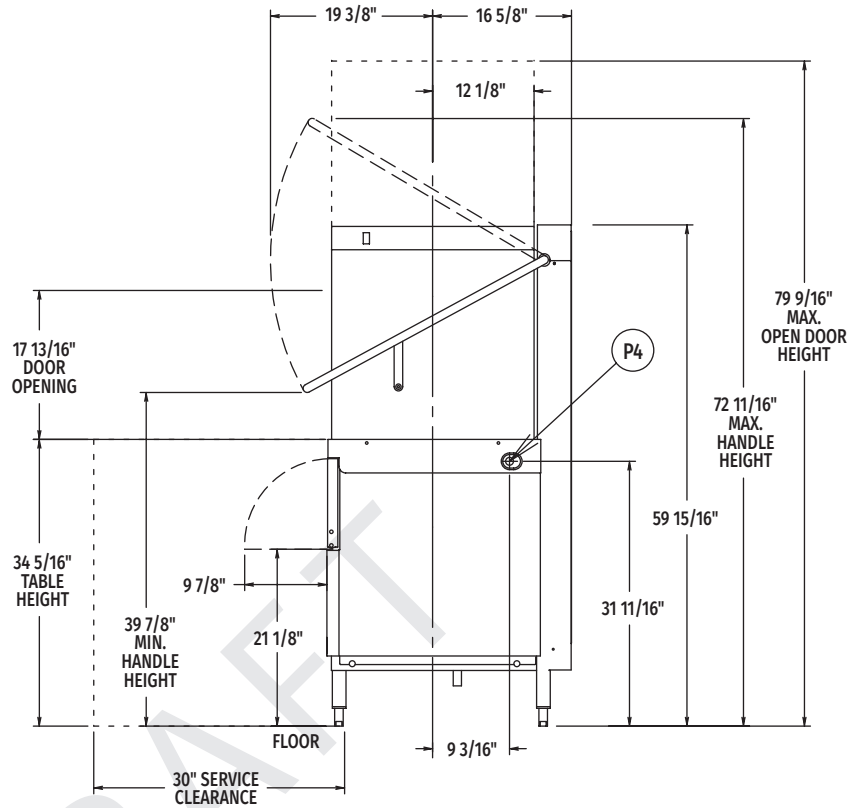

Right Side View

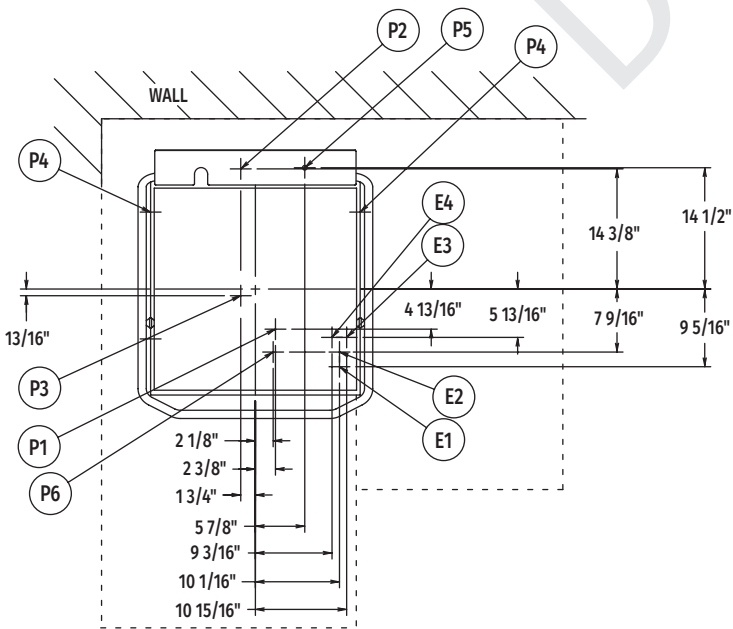

Top View

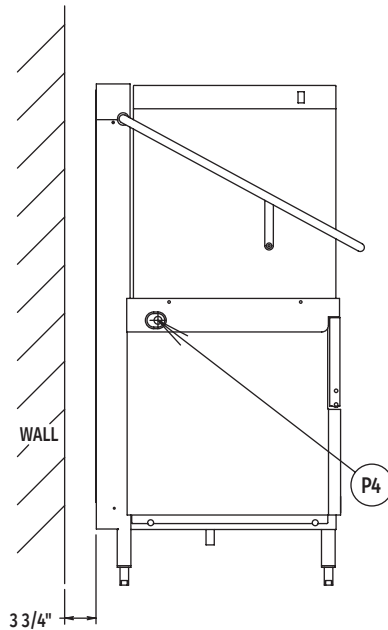

Left Side View

MODEL:
AM-TL
00-950444



AMTL TWO LEVEL ELECTRIC

High Temperature Door-Style Dishwashing Machine

WARNING: Plumbing and electrical connections should be made by qualified personnel who will observe all the applicable plumbing, sanitary, safety codes and National Electrical Code.

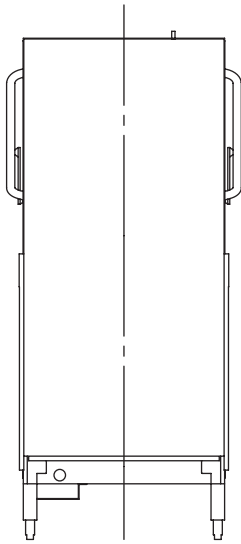

Rear View

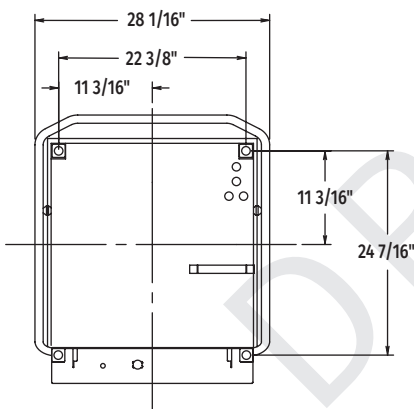

Bottom View

LEGEND

| Electrical Connections | |
|------------------------|--|
| E1 | Electrical connection: wash pump motor & sump heater, 1" or 3/4" conduit hole; 6-11/16" AFF. |
| E2 | Electrical connection: electric booster & controls only or single point electrical connection (3PH only), 1" or 3/4" conduit hole; 6-11/16" AFF. |
| E3 | Electrical connection: detergent & rinse agent feeders, (DPS1 & DPS2) 1.5 amps @ nameplate supply voltage, (RPS1 & RPS2) 1.5 amps @ nameplate supply voltage; 1/2" conduit hole, 6-11/16" AFF. |
| E4 | Electrical connection: vent fan control (VFC1 & VFC2) switching circuit only 1.5 amps @ nameplate supply voltage; 1/2" conduit hole, 6-11/16" AFF. |
| Plumbing Connections | |
| P1 | Common water connection including booster heater: 120°F water minimum; 15-65 PSI recommended, 3/4" female garden hose fitting on 6' long hose supplied with machine; 7-11/16" AFF. |
| P2 | Drain connection: 5/8" barb fitting with 6.5' long hose supplied with machine; 6-11/16" AFF. Maximum height 40" AFF. |
| P3 | Detergent probe sensor: remove cap and stud assembly to access 7/8" hole; 11-1/2" AFF. |
| P4 | Detergent feeder: two locations available; remove cap and stud assembly to access 7/8" hole; 31-11/16" AFF. |
| P5 | Rinse agent feeder: remove 1/8" NPT pipe plug to access 1/8" NPT tapped hole; 60-3/4" AFF. |
| P6 | Cold water connection: 55°F water minimum (drain water tempering accessory - when ordered); 3/4" female garden hose fitting on 8' long hose; 7-11/16" AFF. |

SPECIFICATIONS

Capacities

| | |
|--|-------|
| Racks Per Hour (maximum) | 80 |
| Dishes per Hour (average 25 per rack) | 2,000 |
| Glasses per Hour (average 45 per rack) | 3,600 |
| Wash Tank (U.S. gallons) | 7.9 |

Motor Horsepower

| | |
|-----------------|------|
| Rinse Pumps (2) | 0.18 |
| Wash Pump | 2 |
| Drain Pump | 0.21 |

Rinse

| | |
|--|------|
| Gallons per Rack Upper Chamber | 0.62 |
| Gallons per Rack Lower Chamber | 0.62 |
| Gallons per Hour (maximum consumption) | 49.6 |

Peak Rate of Drain Flow

| | |
|--|----|
| Gallons per Minute (initial rate with full tank) | 11 |
|--|----|

Heating

| | |
|---------------------------------|------|
| Electric Booster (kW) | 12.2 |
| Electric Tank Heating Unit (kW) | 9 |

Exhaust Requirements 450 CFM

Shipping Weight (approximate) 555 lbs.

Crated Dimensions 35.4"L x 39.4"W x 70.9"H



AMTL TWO LEVEL ELECTRIC

High Temperature Door-Style Dishwashing Machine

| E1 AMTL with Electric Sump Heat (When Field Converted to Dual Point) | | | |
|---|------------|---------------------------------|---------------------------|
| Voltage | Rated Amps | Minimum Supply Circuit Ampacity | Maximum Protective Device |
| 208-240/60/1 | 37.7 | 50 | 50 |
| 208-240/60/3 | 21.7 | 25 | 25 |

| E2 12.2 kW Electric Booster & Controls (When Field Converted to Dual Point) | | | |
|--|------------|---------------------------------|---------------------------|
| Voltage | Rated Amps | Minimum Supply Circuit Ampacity | Maximum Protective Device |
| 208-240/60/1 | 54.5 | 60 | 60 |
| 208-240/60/3 | 32.9 | 40 | 40 |

| E2 AMTL Single Point Electrical Service Connection as Shown Below | | | |
|---|------------|---------------------------------|---------------------------|
| Voltage | Rated Amps | Minimum Supply Circuit Ampacity | Maximum Protective Device |
| 208-240/60/3 | 54.9 | 60 | 60 |

| Approximate Heat Gain to Space without Vent Hood | |
|--|---------|
| Type | BTU/Hr. |
| Latent | 9,600 |
| Sensible | 4,900 |

Plumbing Notes: Water hammer arrestor (meeting ASSE-1010 standard or equivalent) to be supplied (by others) in common water supply line at service connection.

Recommended water hardness to be 3 grains or less for best results.

Recommended building flowing water pressure to the dishwasher is 15-65 PSI. Pressures lower than 15 PSI may affect machine fill/start-up times.

This is a pumped rinse machine. Pressure regulating valve is recommended if pressure is higher than 65 PSI (supplied by others).

For convenience when cleaning, water tap should be installed near machine with heavy duty hose and squeeze valve.

Miscellaneous Notes: All dimensions taken from floor line may increase 5/16" or decrease 15/16" depending on leg adjustment. Vent hood (if required) to provide a minimum 450 CFM exhaust (ref installation instructions).

Net weight of machine including booster: 305 lbs.

Domestic shipping weight including booster: 555 lbs.

Size of racks – 19¾" x 19¾".

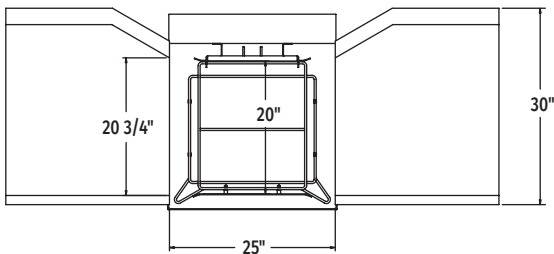

Pass Thru Installation

Top Inside View of Machine

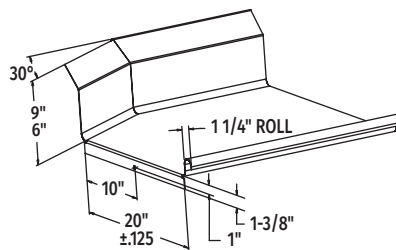

Suggested Table Design

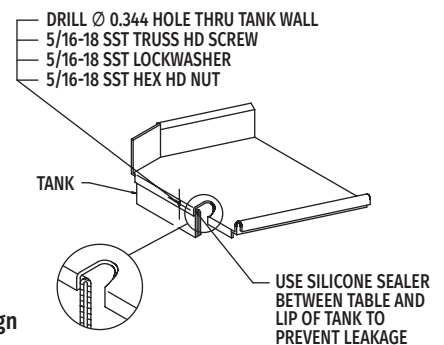

As continued product improvement is a policy of Hobart, specifications are subject to change without notice.