



Project _____
 AIA # _____ SIS # _____
 Item # _____ Quantity _____ C.S.I. Section 114000



LXeH HOT Undercounter



STANDARD FEATURES

- + 32 racks per hour
- + .74 gallons of water per rack
- + Hot water sanitation unit
- + Low chemical alert indicators
- + Sense-A-Temp™ booster heater capable of 70° rise
- + Delime notification with cycle
- + Chemical pump “auto-prime”
- + Service diagnostics
- + Deep drawn stainless steel tank
- + Microcomputer, top mounted controls with digital cycle/temperature display
- + Revolving upper and lower interchangeable anti-clogging wash arms
- + Revolving upper and lower rinse arms
- + Removable stainless steel scrap screen
- + Corrosion resistant pump
- + Automatic pumped drain
- + 17" door opening
- + Automatic fill
- + Detergent and rinse aid pumps standard
- + Electric tank heat
- + Two dishracks – one peg and one combination rack

OPTIONS & ACCESSORIES (Available at extra cost)

- Power cord kits
- Stainless steel base with 6" legs
- 17" stainless steel stand with storage
- External low height caster kit
- Internal caster kit (3")
- DWT-LXe drain water tempering kit – to comply with plumbing codes
- Splash reduction panels
- Water hammer arrestor kit
- Pressure regulator valve



SPECIFIER STATEMENT

Specified unit will be a NSF rated high temperature undercounter dishwasher operating on a hot water supply only with a 17" door opening. Features low chemical and delime notifications, .74 gallons per rack, LED temp and operator display, service diagnostics, rinse aid and detergent pumps. Constructed of stainless steel.

1-year parts and labor warranty.

LXe SERIES – LXeH HOT

Approved by _____ Date _____ Approved by _____ Date _____

LEGEND

Electrical Connections	
E1	Electrical connection: 1-3/8" dia. hole for 1" trade size conduit; 4-5/8" AFF.
Plumbing Connections	
P1	Single fill and rinse connection: 3/4" female garden hose fitting on 6' long hose supplied with machine; 110°F water min. for LXeH.
P2	Drain connection: 5/8" barb fitting with 6' long hose supplied with machine.

WARNING: Plumbing and electrical connections should be made by qualified personnel who will observe all the applicable plumbing, sanitary, safety codes and National Electrical Code.

Required flowing pressure to the dishmachine is 15-65 PSIG. If pressures higher than 65 PSIG are present, a pressure regulating valve must be installed in the water line to the dishmachine (by others).

Pressure gauge not required on pumped rinse machines.

Miscellaneous Notes: Backflow prevention provided by NSF-approved air gap device.

(E1) STANDARD ELECTRICAL OPTIONS

Tank Heat, Booster, Pump & Controls			
Voltage	Rated Amps	Minimum Supply Circuit Ampacity	Maximum Protective Device
208-240/60/1	30.5	40	40
120/208-240(3W)60/1*	30.5	40	40
208-240/60/3	23.9	30	30
220-240/50/1	30.5	40	40

NOTE: For supply connections, use copper wire only rated at 90°C minimum.

*This system requires three power wires which includes a current carrying neutral, an additional fourth wire must be provided for machine ground.

Accessory cord kit available for all machines.

Dishmachine not provided with internal GFCI protection.

SPECIFICATIONS

Capacities

Cycle Time (seconds)	109
Racks per Hour	32
Tank Capacity – Gallons	2.9

Motor Horsepower

Wash	0.85
Rinse	0.19

Water Consumption

U.S. Gallons per Rack (maximum use)	0.74
U.S. Gallons per Hour (maximum use)	23
Peak Drain Flow – U.S. Gallons (gallons per minute)	4.0

Temperatures °F

Wash	150
Rinse	180
Incoming Water Temperature (minimum recommended)	110

Heating

Tank Heat, electric (kW)	1.8
Electric Booster (kW)	4.9

Standard 20" x 20" (508 x 508) Rack Complement

Flat	1
Peg	1

Shipping Weight (approximate) 170 lbs.

Crated Dimensions. 28"W x 30"L x 37"H

Heat Output, BTU/Hour	
Latent	Sensible
4,600	4,000

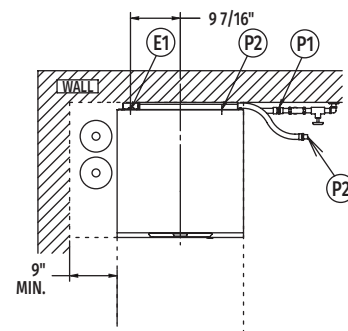

Top View

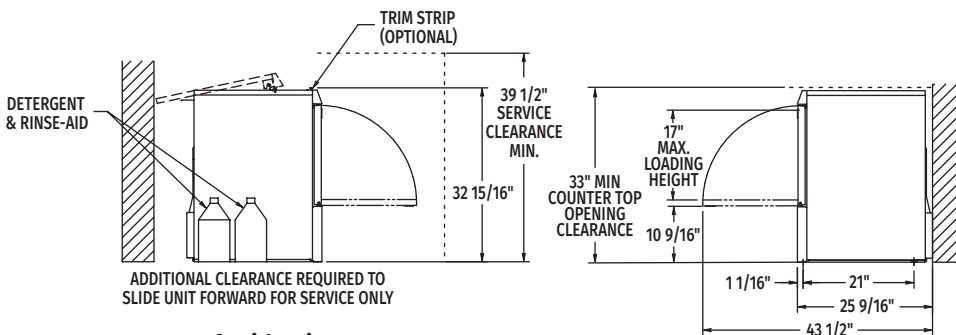

Left Side View

Right Side View

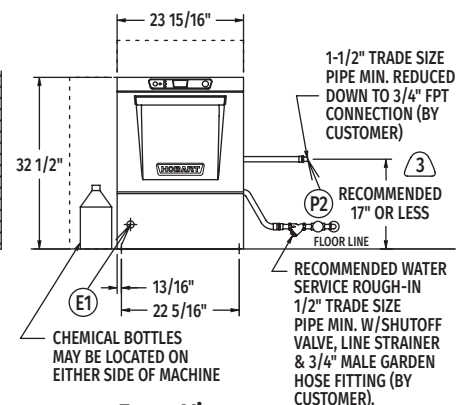

Front View

MODEL:
LXeH
00-947871
REV C