

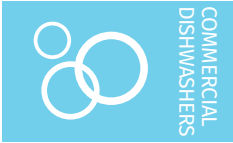

Project \_\_\_\_\_  
 AIA # \_\_\_\_\_ SIS # \_\_\_\_\_  
 Item # \_\_\_\_\_ Quantity \_\_\_\_\_ C.S.I. Section 114000



## CLCS66eN-BAS GAS

### High Temperature Corner Scrapper Rack Conveyor Dishwashing Machine

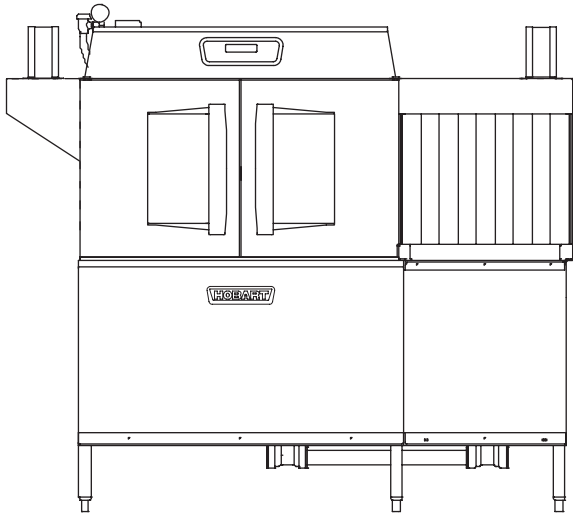

#### STANDARD FEATURES

- + 202 racks per hour
- + 22" power scrapper
- + Opti-Rinse™ system
- + Rapid return conveyor drive mechanism
- + Large double door opening for ease of cleaning
- + Doors are insulated & hinged with door interlock switches
- + 19.5" chamber height opening (accepts sheet pans)
- + Top mounted micro-processor control module
- + Energy saver mode (programmable auto-shut down)
- + Dirty water indicator
- + Manager activated low temperature alert
- + NSF rated configurable pot and pan dwell mode
- + Configurable "intelligent" delime notification
- + Service diagnostics
- + Self-aligning wash manifolds
- + Stainless steel anti-clogging wash arms
- + Removable pump intake screen
- + Stainless steel self-draining pump and impeller
- + Single, sloping scrap screen and deep scrap basket
- + Stainless panels enclose perimeter and bottom
- + Door actuated drain closure
- + Convertible hot water or low temp final rinse
- + Vent fan control
- + Booster heater control
- + ENERGY STAR® Certified

CLEAN SERIES – CLCS66eN-BAS GAS



#### SPECIFIER STATEMENT

Specified dishwasher will be Hobart CLCS66eN Base gas tank heat model with corner scrapper and Opti-Rinse™. Includes 22" power scrapper, dirty water indicator, configurable "intelligent" de-lime notification, insulated ergonomic cabinet style doors, top mounted computer controls, and NSF approved pot and pan cycle mode. The wash tank utilizes durable precision pressure sensor monitors in lieu of conventional mechanical floats.

#### OPTIONS & ACCESSORIES (Available at extra cost)

- Standard, short, and extended stainless steel vent hoods
- Internal stainless steel pressure-less 30 kW booster heater field convertible to 15 kW (booster includes PRV)
- Direct drive unloader – adds 38" length. Reference spec F39520 for more details
- Side loader – SL23 adds 23" length, SL30 adds 30" length. Reference specs F40926 and F40927 for more details
- Blower-dryer – adds 33¾" to length. Reference spec F40252 for more details (ships separate from dishmachine, contact Hobart Service for installation)
- Drain water tempering kit (field installed)
- Flanged feet kit (requires two kits)
- Higher than standard chamber (24" opening)
- Table limit switch with 10' wire
- Correctional package (contact Hobart for details)
- Pressure regulator valve (PRV), for use with external booster
- Water shock absorber kit
- Factory-mounted circuit breakers (contact Hobart for details)
- Common electrical connection (see page 4)

Approved by \_\_\_\_\_ Date \_\_\_\_\_ Approved by \_\_\_\_\_ Date \_\_\_\_\_



# CLCS66eN-BAS GAS

## High Temperature Corner Scrapper Rack Conveyor Dishwashing Machine

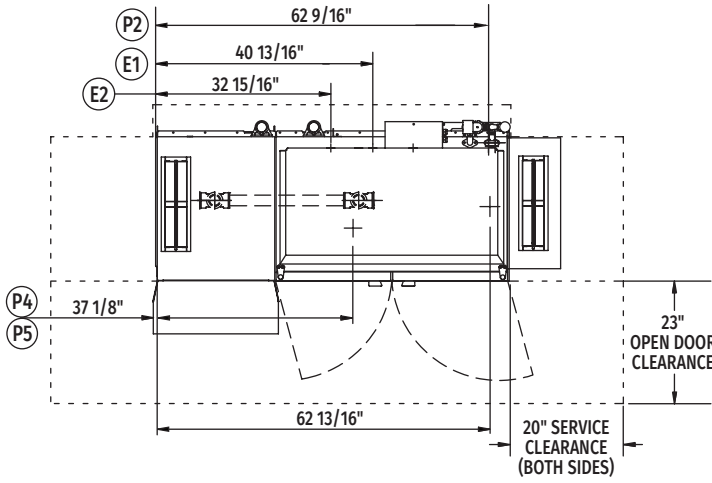

Top View Left to Right

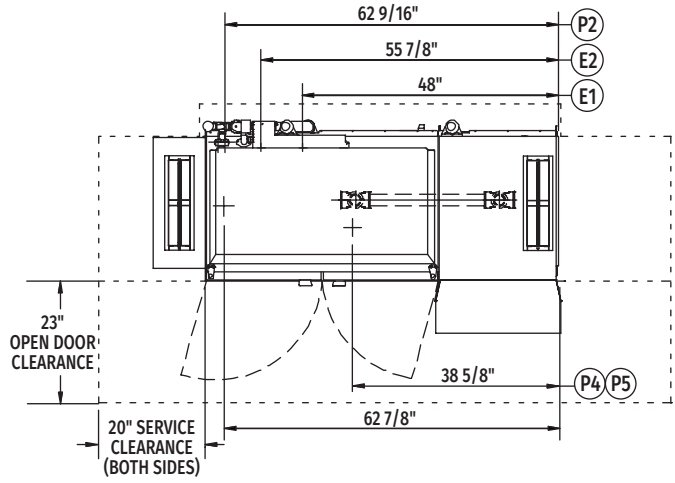

Top View Right to Left

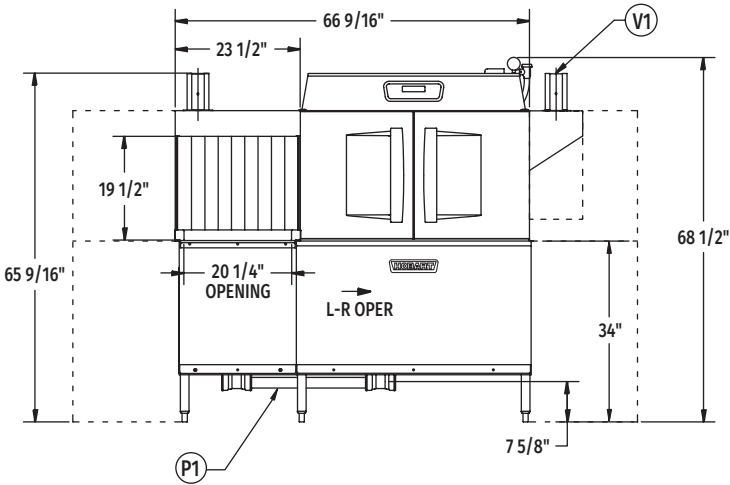

Front View Left to Right

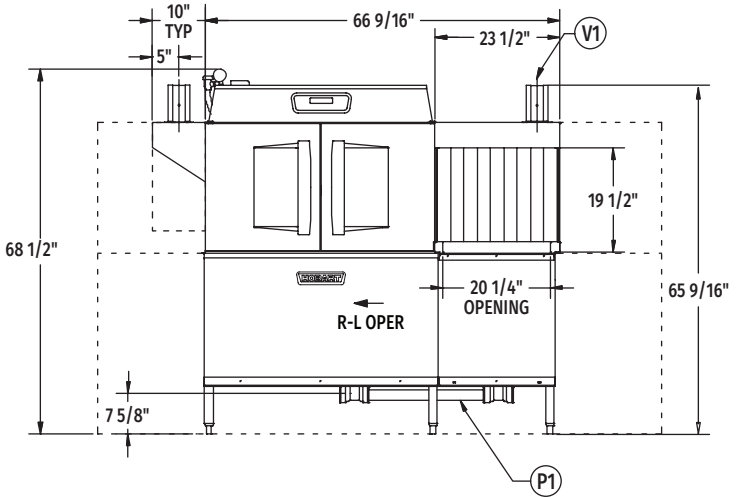

Front View Right to Left

### VENT HOOD OPTIONS

(Adjustable, vent stack can be adjusted 1" to either side)

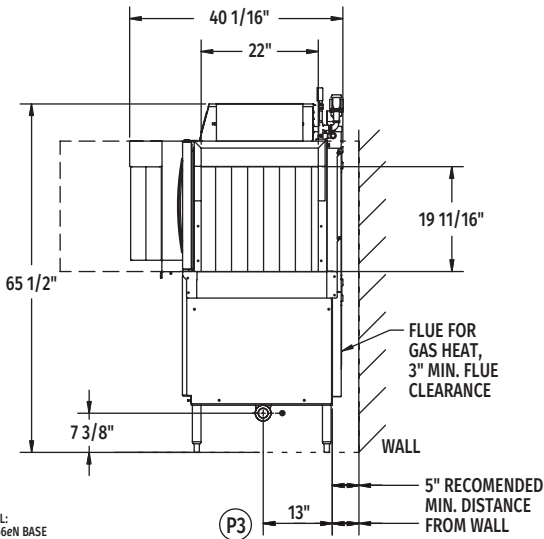
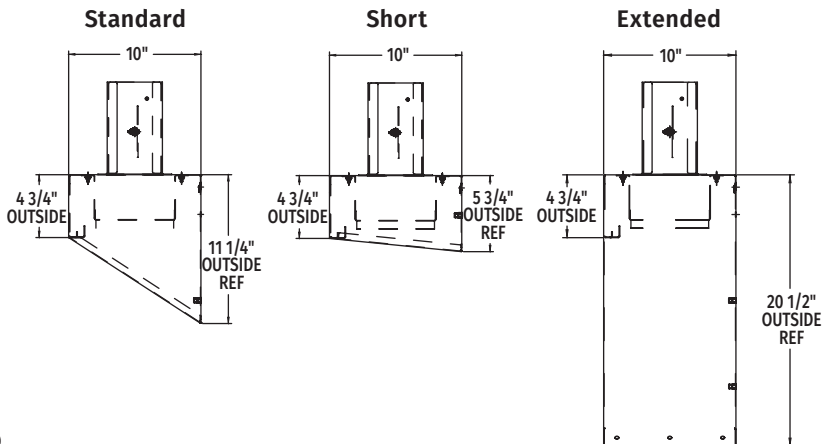

Side View

Reference page 4  
for installation drawings

MODEL: CLCS66eN BASE  
L-R OPERATION  
D-974813  
REV B

MODEL: CLCS66eN BASE  
R-L OPERATION  
D-974812  
REV B



# CLCS66eN-BAS GAS

## High Temperature Corner Scrapper Rack Conveyor Dishwashing Machine

### LEGEND

Electrical Connections	
E1	Motors and controls 1-1/4" or 2" conduit, 63-3/4" AFF.
E2	Internal electric booster, 1-1/4" or 2" conduit, 63-3/4" AFF.
<b>NOTE:</b> Common electrical connection (single point) available, see page 4 for details. Booster information, see page 4.	
Plumbing Connections	
P1	Drain. May be drained to either side of valve, plug opposite side 2" FPT. Recommend a floor drain minimum of 12" from machine for access and maintenance. 7-3/8" AFF.
P2	Hot water. 1/2" FPT connection. 1/2", 11-3/16" AFF. See plumbing notes for required temperatures.
P3	Optional cold water connection for drain water tempering 1/2" FPT, cold water temperature 80°F, maximum 7-3/8" AFF.
Gas Connections (Natural Gas P4 or L.P. P5)	
P4	Gas connection – natural, 1/2" FPT, 10-3/4" AFF; 3.5" minimum, 7" maximum W.C. incoming.
P5	Gas connection – L.P., 1/2" FPT, 10-3/4" AFF; 8" minimum, 11" maximum W.C. incoming.
Vent Connections	
V1	Optional vent hoods, 4" x 16" vent stack with damper.

**WARNING:** Plumbing and electrical connections should be made by qualified personnel who will observe all the applicable plumbing, sanitary, safety codes and National Electrical Code.

**WARNING:** Gas heat machines must be provided with a means to exhaust the flue gases to the exterior of the building.

**Plumbing Notes:** Minimum incoming water temperatures: 110°F for 30kW internal booster, 140°F for 15kW field converted internal booster, 180°F without internal booster. Building flowing water pressure to dish machine is 20 PSI, (+/- 5 PSI). For non-booster machines, a PRV with internal expansion bypass is required.

If gas pressure is higher than 7" (Natural) or 11" (LP) W.C., a pressure regulating valve must be installed (by others) in the gas line to the dish machine.

### SPECIFICATIONS

#### Capacities

Racks per Hour (NSF rated) . . . . .	202
Wash Tank (U.S. gallons) . . . . .	23
Power Scrapper (U.S. gallons) . . . . .	23
Conveyor Speed (feet per minute) . . . . .	5.6

#### Motor Horsepower

Drive . . . . .	1/6
Wash . . . . .	.2
Power Scrapper . . . . .	.2

#### Water Consumption

U.S. Gallons per Hour (maximum use at 20 PSI) . . . . .	126
U.S. Gallons per Rack . . . . .	0.62
Peak Drain Flow (U.S. gallons per minute) . . . . .	38

#### Heating

Tank Heat, LP or Natural Gas (BTU per hour) . . . . .	78,000
Optional Electric Booster (built-in) (kW for 40°F rise) . . . . .	15
Optional Electric Booster (built-in) (kW for 70°F rise) . . . . .	30

#### Venting

Load End (minimum CFM) . . . . .	200
Unload End (minimum CFM) . . . . .	400
(Gas exhaust venting must be installed according to local code)	

**Shipping Weight (approximate)** . . . . . 855 lbs.

**Crated Dimensions.** . . . . . 76"L x 38"W x 78"H

E1	Electrical Connection (3 PH only) Motors and Controls			
	Voltage	Rated Amps	Minimum Supply Circuit Ampacity	Maximum Protective Device
	208/60/3	16.3	20	20
	240/60/3	16.3	20	20
	480/60/3	9.4	15	15
	600/60/3	8.4	15	15

CLCS66eN-BAS Gas Heat Dissipation		
Booster	BTU/HR.	
	Latent	Sensible
Without Booster	22,900	9,800
15kW Booster	36,400	15,600
30kW Booster	50,000	21,400



# CLCS66eN-BAS GAS

## High Temperature Corner Scrapper Rack Conveyor Dishwashing Machine

Booster Heat 30 kW (Standard) Minimum 110°F Incoming Water				
E2	Voltage	Rated Amps	Minimum Supply Circuit Ampacity	Maximum Protective Device
	208/60/3	83.9	90	90
	240/60/3	80.2	90	90
	480/60/3	40.1	50	50
	600/60/3	33.7	40	40

Booster Heat 15 kW (Field Convertible) Minimum 140°F Incoming Water				
E2	Voltage	Rated Amps	Minimum Supply Circuit Ampacity	Maximum Protective Device
	208/60/3	45.0	60	60
	240/60/3	40.1	50	50
	480/60/3	20.0	25	25
	600/60/3	13.5	20	20

### COMMON ELECTRICAL CONNECTION (SINGLE POINT) – CONTACT FACTORY FOR ADDITIONAL INFORMATION

Common Electrical Connection (Includes Motors & Controls and Electric Booster Heater)						
Voltage	MACHINE AND 15kW BOOSTER			MACHINE AND 30kW BOOSTER		
	Rated Amps	Minimum Supply Circuit Ampacity	Maximum Protective Device	Rated Amps	Minimum Supply Circuit Ampacity	Maximum Protective Device
208/60/3	61.3	80	80	100.2	110	110
240/60/3	61.3	80	80	100.2	110	110
480/60/3	29.4	40	40	49.5	70	70
600/60/3	21.9	35	35	42.1	55	55

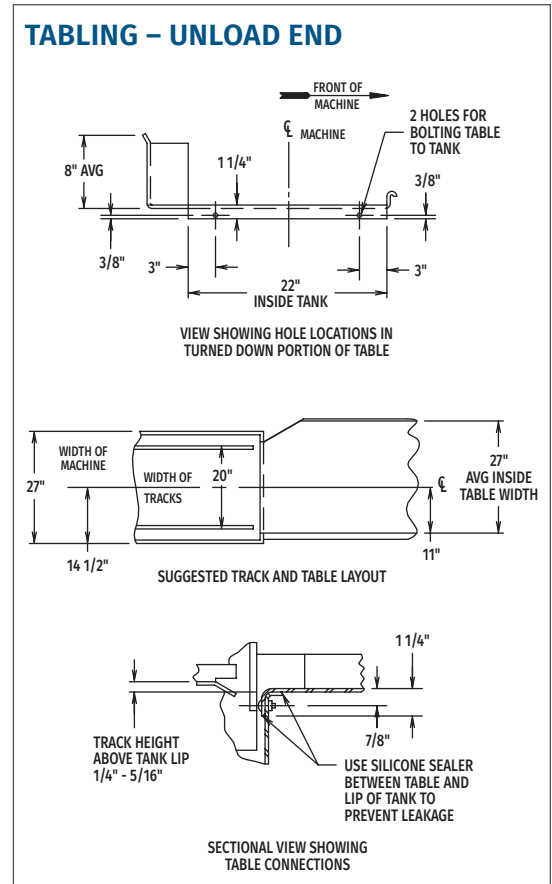
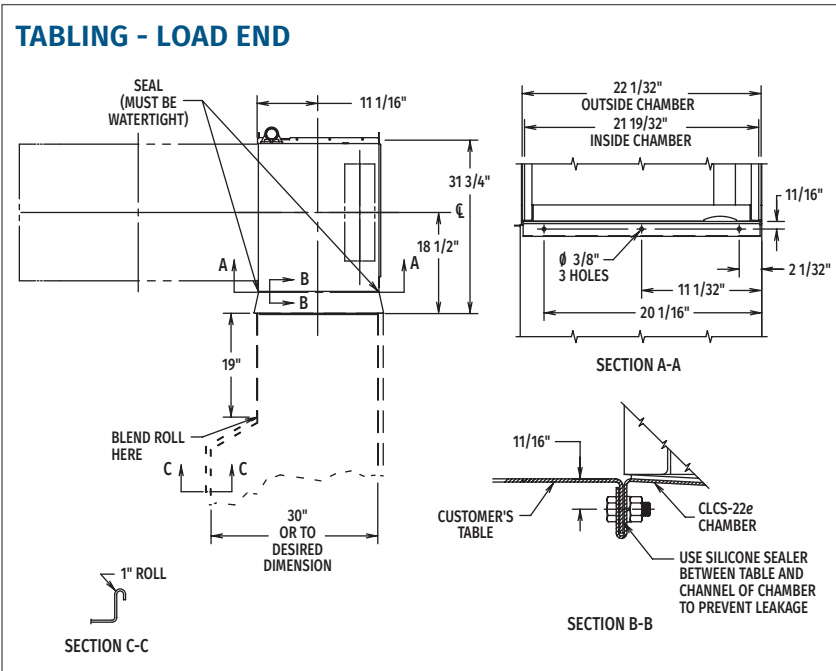

As continued product improvement is a policy of Hobart, specifications are subject to change without notice.