



OWNER'S MANUAL



R-Series

- Reach-in, pass-thru, roll-in & roll-thru refrigerators
- Reach-in & roll-in freezers
- Reach-in refrigerator/freezer dual temperature units
- Reach-in, pass-thru, roll-in & roll-thru hot food holding cabinets

NOTE: This manual is intended for use with the above referenced equipment manufactured after July 1, 2025. To obtain a copy of the correct Owner's Manual to support the same product manufactured prior to this date, please contact Traulsen's service department at (800) 825-8220.

4401 Blue Mound Road Fort Worth, Texas 76106 (USA)
Phone: 800.825.8220 | Service Fax: 817.740.6757 | E-mail: service@traulsen.com | Website: traulsen.com

Hours Of Operation: Monday - Friday 7:30 a.m. - 4:30 p.m. (CST)







Table of Contents

I. The Serial Tag		V. Care & Maintenance	Page 5
II. Receipt Inspection	Page 2	VI. Control Basics	Page 7
III. Installation	Page 2	VII. Troubleshooting Guide	Page 11
IV. Operation	Page 5	VIII. Service/Warranty	Page 12

I. The Serial Tag

Location:

The serial tag is a permanently affixed label on which is recorded vital electrical and refrigeration data about your Traulsen product, as well as the model and serial number. This tag is located in the upper right interior compartment on all reach-in/pass-thru and roll-in/roll-thru refrigerator, freezer and dual-temp models. For hot food models, this tag is located on the top of the unit behind the louvers to protect it from the heat.

		ITW Food Equipment Group, LLC North American Refrigeration 4401 Blue Mound Rd. Ft. Worth, TX 76106 800-825-8220		
		MODEL: MODELO: MODELE:		RDT232WUT-FHS
SERIAL NUMBER:		25F		SCAN FOR SERVICE INFO
REFRIGERANT / REFRIGERANTE / RÉFRIGÉRANT				
SYS1 (REFM):	R-290	3.80 OZ	107.71 g	107,71 g
HI Press. (PRESH):		360.00 psi	2,482.11 kPa	2,482,11 kPa
Lo Press. (PRESL):		130.00 psi	896.32 kPa	896,32 kPa
SYS2 (REFA):	R-290	3.00 OZ	85.04 g	85,04 g
HI Press. (PRESH):		460.00 psi	3,171.59 kPa	3,171,59 kPa
Lo Press. (PRESL):		140.00 psi	965.27 kPa	965,27 kPa
Input Power (ELIN) - FOR INDOOR USE ONLY				
Voltage	Hertz	Phase	Total Amps	
115 ~	60	1	12.60	
Device/Part Number:		Device/Part Notes:		
     				
COMPONENTS / COMPOSANTS / COMPONENTES				
	1	2	MAX OVER CURRENT PROTECTION (A):	
COMP AMPS:			MIN CIRCUIT IN AMPS:	
COND FAN AMPS:			DOME LIGHT WATTS: 11	
EVAP FAN AMPS:			DISPLAY LIGHT WATTS:	
CONTROL AMPS:			DOOR HEATER WATTS:	
DEF HEATER WATTS:			B/TMCE HTR WATTS:	
370-60297-00 REV. D 01/15/2024				

Reading the Serial Tag

- Serial = The permanent ID# of your Traulsen
- Model = The model # of your Traulsen
- Refrigerant SYS1 = Refrigerant Type & Charge
- Refrigerant SYS2 = Refrigerant Type & Charge
- Volts = Voltage
- Hertz = Cycle
- Total Current = Maximum amp draw
- Minimum Circuit Amps = Minimum circuit ampacity
- Lights = Light wattage
- Heaters
- Refrigerant = Refrigerant type used
- Design Pressure = High & low side operating pressures and refrigerant charge
- Agency Labels = Designates agency listings

II. Receipt Inspection

All Traulsen products are factory tested for performance and are free from defects when shipped. The utmost care has been taken in crating this product to protect against damage in transit. All interior fittings have been carefully secured and the legs or casters are boxed and strapped inside to prevent damage. Door keys will be attached to the handle with a nylon strip. The handle is protected by an easily removable nylon netting.

You should carefully inspect your Traulsen unit for damage during delivery. If damage is detected, you should save all the crating materials and make note on the carrier's Bill Of Lading describing the damage. A freight claim should be filed immediately. If damage is subsequently noted during or immediately after installation, contact the respective carrier and file a freight claim. There is a five (5) day limit to file freight damage with the carrier. Under no condition may a damaged unit be returned to Traulsen without first obtaining written permission (return authorization). You may contact Hobart/Traulsen customer care at 800-333-7447 to request a return.

Systems Using Refrigerant R-290 (Propane)

Traulsen has selected propane as the refrigerant for many of their products. In addition to its low global warming potential and impact on the environment, propane is an ideal refrigerant. It is a flammable refrigerant, however, which is why you will see a "flammable refrigerant" sticker on applicable products. Traulsen products using propane as the refrigerant are ETL approved and are safe to use in accordance with this Owner's Manual and general industry practices for commercial cooking environments. Please check with local codes or regulations for any restrictions to products using hydrocarbon refrigerants.

III. Installation

Location

Select a proper location for your Traulsen unit, away from extreme heat or cold. Allow enough clearance between the unit and the side wall in order to make use of the door stay open feature at 120° (self-closing feature operates up to 90°). The door(s) must be able to open a minimum of 90° in order to make use of the maximum clear door width available.

Packaging

All Traulsen units are shipped from the factory bolted to a sturdy wooden pallet and packaged in a durable cardboard container. The carton is attached to the wooden skid with the use of large staples. These should first be removed to avoid scratching the unit when lifting off the crate.

Most exterior stainless-steel surfaces have a protective vinyl covering to prevent scratching during manufacturing, shipping and installation. After the unit is installed in place of service, remove and discard the covering from all surfaces.

To remove the wooden pallet, first, if at all possible, we suggest that the cabinet remain bolted to the pallet during all transportation to the point of final installation. The bolts can then be removed with a 3/4" socket wrench. Avoid laying the unit on its front, side or back for removal of the pallet.

NOTE: DO NOT LAY THE UNIT ON ITS SIDE DURING TRANSPORTATION OR INSTALLATION.

Roll-thru models also include special interior wood bracing, intended to protect the cabinet during shipment. This bracing should under no circumstances be removed prior to the unit being installed in its final location.

▲ WARNING Read and review these instructions, in their entirety, **BEFORE** attempting to disassemble and remove the interior bracing.

If either of the diagonal or upper ceiling braces are dropped, they could cause personal injury or damage to the equipment. To disassemble the bracing, first open the doors and carefully remove the banding that holds the two diagonal braces together.

To disassemble the bracing, first open the doors and carefully remove the banding that holds the two diagonal braces together.

▲ WARNING The diagonal braces will now be loose and can fall out of position and possibly permit the ceiling corner brace to fall.

Carefully remove one diagonal brace while supporting the ceiling corner brace, so that it does not fall (see figure 1). Next, remove the ceiling brace, the remaining diagonal brace, and lastly the floor brace - then discard. Repeat as necessary for each section of the unit.

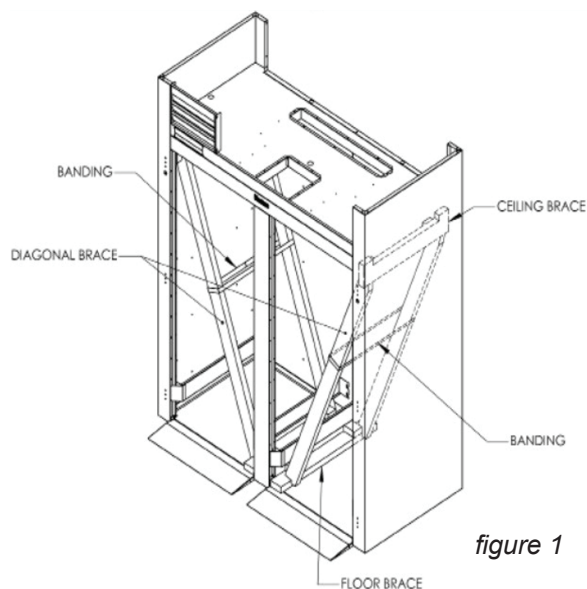

figure 1

Installing Legs or Casters

6" High stainless steel legs are supplied standard for all Traulsen R- Series units. Casters in lieu of legs are available as an optional accessory for the same models. These are shipped from the factory packed inside a cardboard box which is strapped to one of the shelves. Remove the nylon strap and open the box, it should contain either four (4) legs or four (4) casters and sixteen (16) bolts.

▲ WARNING THE CABINET MUST BE BLOCKED AND STABLE BEFORE INSTALLING LEGS OR CASTERS.

To install the legs or casters, first raise and block the reach-in a minimum of 7" from the floor. For installing legs, thread the legs into the threaded holes on the bottom of the cabinet (see figure 2). Be certain that all legs are tightly secured (legs and casters should be tightened to 300 inch/pounds, max). When the unit is set in its final position, it is important for proper operation that the unit be level. The legs are adjustable for this purpose; turn the bottom of the leg counter-clockwise to raise it, clockwise to lower it. Level the unit from front to back as well as side to side in this manner, using a level placed in the bottom of the cabinet.

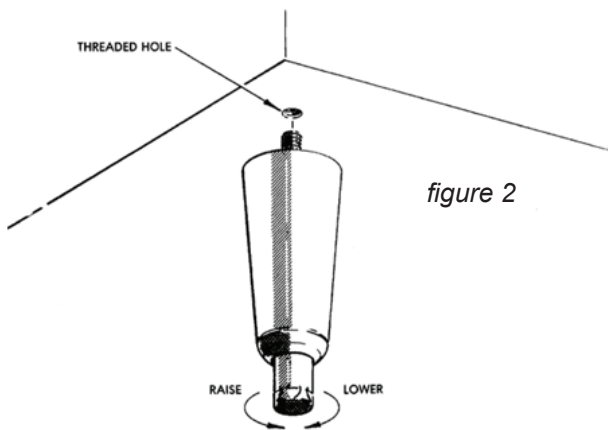

figure 2

Please note that Traulsen units are not designed to be moved while on legs. If the unit requires moving, a pallet jack or forklift should be used to prevent damage. For installing casters, the casters are "plate" type, and require the use of four (4) bolts each to secure them firmly to the cabinet bottom at each corner (see figure 3). The caster bolts are tightened using a 1/2" socket wrench.

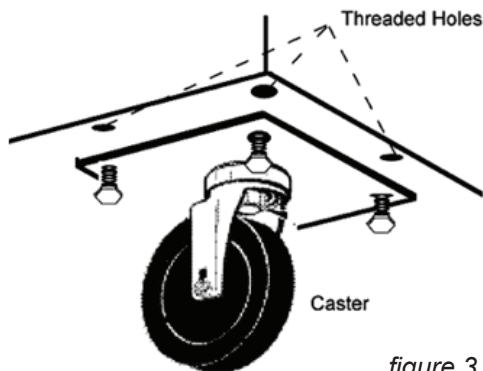

figure 3

Shelf Pins

The unit is supplied with shelves and shelf pins installed. Check all shelf pins to assure they are tightened down as they may have come loose during shipping. Rotate the pins clockwise until they are secured against the side of the cabinet.

Shelf Load and Deflection

- Maximum weight per shelf: 120 lbs
- Maximum weight per section: 250 lbs

Slight shelf deflection under load is normal and acceptable. Shelving complies with applicable requirements of UL 60335.

Roll-in Model Installation

Roll-in cabinets set on the floor require the floor area to be flat and level. In addition, after the cabinet is set in place, sealant should be used around the perimeter of the base to comply with National Sanitation Foundation requirements (see figure 4). After sealing the unit, the enclosed ramp should then be installed.

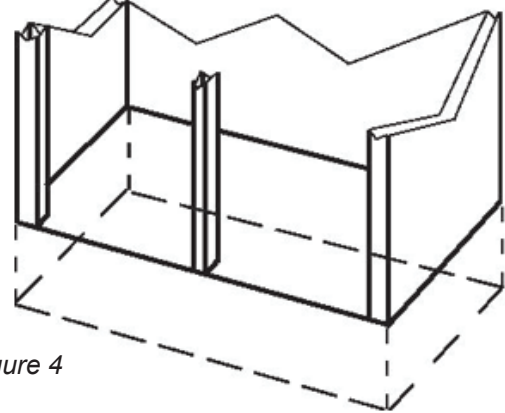

A stainless-steel threshold ramp(s) is included to facilitate roll-in racks. It is shipped wrapped in brown paper and secured to the rack guides inside the cabinet. To secure it in place, remove the two thumb screws in the breaker strip near the bottom door opening. Next, loosen the thumb screws located along the floor at the threshold. Place the ramp(s) on top of the loosened thumb screws and secure tabs on each end to breaker strips with thumb screws previously removed. After installing the ramp(s), it too should be sealed to the floor.

Bumper strips are secured to the back of roll-in models with thumb screws. Loosen these and make them finger tight to conform with the requirements of the National Sanitation Foundation (NSF).

Installing the Condensate Evaporator

A condensate evaporator is normally supplied on all self-contained models (remote models require provision of either a floor drain or an optional condensate evaporator). On those models supplied with a top-mounted evaporator coil compartment, the condensate evaporator is also secured to the top of the cabinet. Check that the condensate pan is properly located underneath the drain tube.

NOTE: Some models, such as single section dual- temperature refrigerator/freezers, are supplied with a bottom-mounted condensate evaporator. This is shipped in a cardboard carton secured to the cabinet interior and must be properly installed prior to use (see instructions supplied with the condensate evaporator).

1. After the cabinet has been uncrated and the legs/ casters attached, you must install the bottom-mounted condensate evaporator (see figure 5).
2. Locate the four (4) holes on the exterior bottom towards the rear of the cabinet.
3. Using the provided 10-32 screws, attach the mounting rails to the bottom, (the folded flange is to be turned up and be towards the drain line).
4. Slide condensate pan into the mounting rails.
5. Screw the “U-Trap” on to the drain line located on the rear of the cabinet.
6. Screw the drain extension into the “U-Trap”.

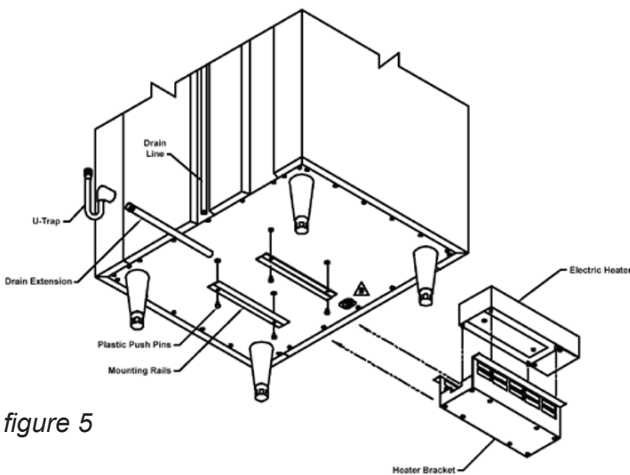

figure 5

NOTE: The use of the “U-TRAP” supplied is required. Failure to use this component may allow cold air to migrate down the drain line, resulting in condensation on the rear of the cabinet. A remote model is normally supplied configured for condensate to be run to a floor drain unless purchased with a condensate evaporator. The installer is responsible for making the required extension to the floor drain in accordance with good practice and local regulations.

Remote Installation

Remote models are supplied without compressors, solenoid valves, etc. The correct voltage, amp listing and refrigerant are listed on the unit's serial tag. It is the responsibility of the installer to specify and supply the correct size compressor(s) based upon this information and on-site requirements. Refrigerant line installation must be done in accordance with good practice and local regulations. See section the previous section for information concerning condensate removal for remote models.

Cord & Plug

Most self-contained models are supplied with a cord & plug attached. It is shipped coiled at the top of the cabinet, secured by a nylon strip. For your safety and protection, all units supplied with a cord and plug include a special three-prong grounding plug on the service cord. Select only a dedicated electrical outlet with grounding plug for power source.

NOTE: Do not under any circumstances, cut or remove the round grounding prong from the plug, or use an extension cord.

Power Supply

The supply voltage should be checked prior to connection to be certain that proper voltage for the cabinet wiring is available (refer to the serial tag to determine correct unit voltage). Make connections in accordance with local electrical codes. Use qualified electricians.

Use of a separate, dedicated circuit is required. Size wiring to handle indicated load and provide necessary overcurrent protector in circuit (see amperage requirements on the unit's serial tag).

Clearance

In order to assure optimum performance, the condensing unit of your Traulsen unit **MUST** have an adequate supply of air for cooling purposes. Therefore, the operating location must either have a minimum of 12” clearance overhead of the condensing unit or allow for unrestricted air flow at the back of the unit. Clearance of at least 12” above is required in order to perform certain maintenance tasks.

IV. Operation

Refrigerators

Neither refrigerators nor freezers require manual defrosting. During normal operation, a refrigerator continuously circulates cool air (34-38°F) across the evaporator coil. A defrost cycle occurs every 8 hours to melt any frost which may have accumulated on the coil. The control will display the cabinet temperature when the defrost started and activate a LED with the defrost symbol on the control display.

Freezers

During normal operation, the freezer continuously circulates below-freezing cabinet air across the evaporator coil to maintain consistent product temperatures. Over time, frost may accumulate on the evaporator coil and must be removed to ensure efficient operation. The freezer is equipped with Predictive Defrost™, an intelligent, demand-based defrost system. Unlike traditional timer-based defrost programs, the smart controller continuously monitors real-time air temperature and humidity conditions inside the cabinet. A defrost cycle is initiated only when necessary, based on actual operating conditions.

This adaptive approach replaces fixed, scheduled defrost intervals with a responsive system that automatically adjusts to usage patterns and environmental conditions.

The control will display the cabinet temperature when the defrost started and activate a LED with the defrost symbol on the display (see figure 13 on page 8). The electric heater (attached to the coil) is energized. When a temperature sensor affixed to the coil senses 45°F (models with electric defrost), the coil is fully defrosted and the compressor operation is resumed, defrost heaters are automatically turned off. The coil fans are delayed from starting at the termination of a defrost cycle. Fan operation is automatically resumed, or they can also be started by a time or temp delay (whichever comes first). In case of temp delay, it uses the same coil sensor and starts at 32°F. The total refrigeration system operation is then resumed.

During freezer defrost operation, heat is confined to the coil enclosure to prevent any significant rise in temperature within the food zone. The fan delay controls function upon termination of a defrost cycle is two-fold. First, to prevent blowing warm air into the food storage area. Second, to prevent any condensation on the defrost coil from being blown into the food storage area. The Smart Control is set from the factory to terminate defrost at 30 minutes in the event of a sensor failure. This setting should never be tampered with, without first consulting the factory.

Hot Food Cabinets

Hot food cabinet operation is governed by the Smart Control™, which controls the ON/OFF operation of the strip heaters. The control can be set to maintain any operational temperature between 130-180° F (in 1 degree increments). Hot food cabinets are delivered from the factory with the control set to the “OFF” position. Follow the instructions in section “VI. The Control” to get started.

NOTE: A vent is included at the top of all hot food cabinets. The vent opening is factory set and secured for best position. Be certain to make sure this vent is kept free of any obstruction.

V. Care & Maintenance

Cleaning the Condenser

▲ WARNING Disconnect the electrical power supply before cleaning any parts of the unit.

The most important thing you can do to insure a long, reliable service life for your Traulsen is to regularly clean the condenser coil.

The condensing unit requires regularly scheduled cleaning to keep the condenser clean of lint and dust accumulation. Keeping the condenser clean allows the cabinet to operate more efficiently and use less energy.

To clean the condenser, first disconnect electrical power to the cabinet and lift up the front louver assembly. To lift this, remove the two screws located on both sides at the bottom of the louver assembly (figure 7).

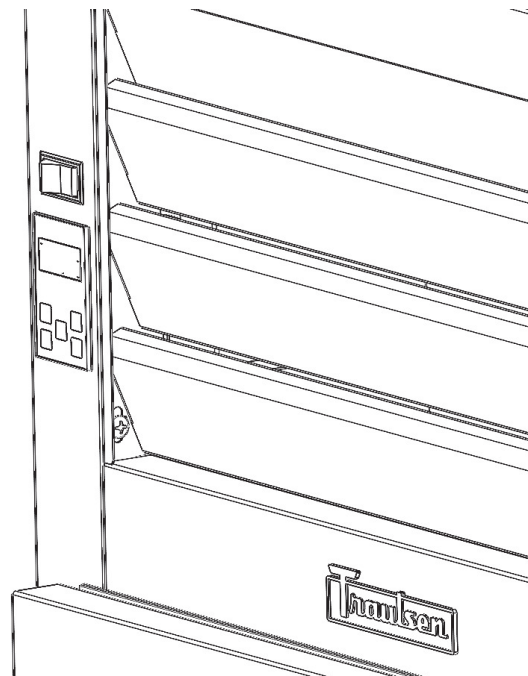

figure 7

Once the screws are removed, the panel can be pivoted upwards allowing full access to the front facing condenser (see figure 8).

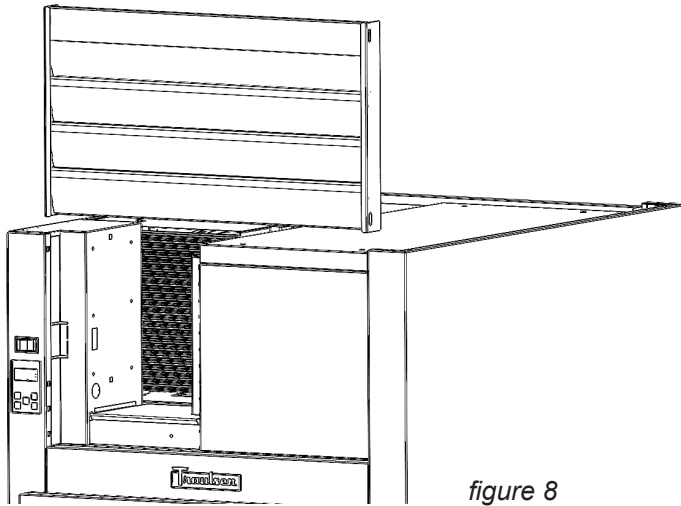

figure 8

Vacuum or brush any dirt, lint or dust from the finned condenser coil, the compressor and other cooling system parts (see figure 9). If significant dirt is clogging the condenser fins, use compressed air to blow this clear. Lower louver assembly and replace the screws to hold it in place.

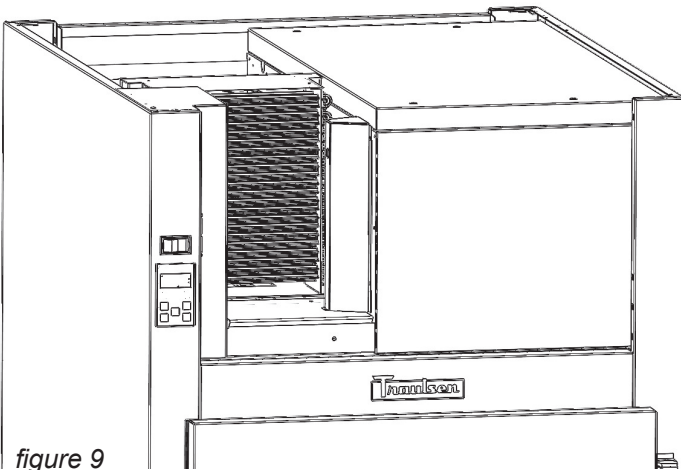

figure 9

Most Traulsen R-Series models come with a StayClear™ condenser coil with a wide-finned design. The StayClear coil does not require regularly scheduled cleanings but should be cleaned every 6 months or when the wide-finned coil presents a certain level of obstruction of significant dirt on the fins. If the StayClear Condenser requires cleaning, follow the same steps for cleaning the finned condenser.

⚠ Systems Using Refrigerant R-290 (Propane) ⚠

Remove any ignition source (arc, flame, heat) before cleaning the condenser coil. If the condenser coil is inadvertently damaged during cleaning to the point of causing a refrigerant leak, immediately ventilate the area and call for service.

Gasket Replacement

To remove the gasket to be replaced, grasp it firmly by one corner and pull it out. Before attempting to install a new gasket, both the unit and the gasket itself must be at room temperature. Insert the four corners first by using a rubber mallet (or hammer with a block of wood). After the corners are properly inserted, work your way toward the center from both ends by gently tapping with a mallet until the gasket is completely seated in place (see figure 10).

NOTE: The gasket may appear too large, but if installed as indicated above, will slip into place.

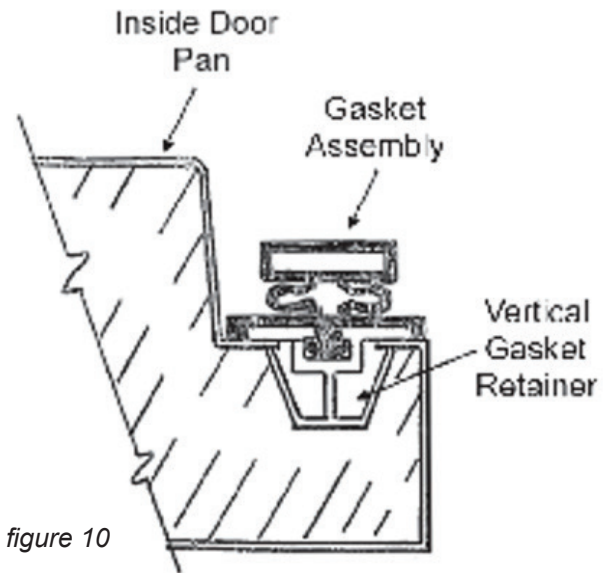

figure 10

Cleaning the Exterior

Exterior stainless-steel should be cleaned with warm water, mild soap and a soft cloth. Apply with a dampened cloth and wipe in the direction of the metal grain. Avoid use of strong detergents and gritty, abrasive cleaners as they may tend to mar and scratch the surface. Do NOT use cleansers containing chlorine- this may promote corrosion of the stainless-steel.

Care should be taken to avoid splashing the unit with water, containing chlorinated cleansers, when mopping the floor around the unit. For stubborn odor spills, use baking soda and water (mix 1 tablespoon baking soda : 1 pint water ratio).

Cleaning the Interior

Interior stainless-steel should be cleaned by using the baking soda/water mixture described in the previous section. Use the mixture on breaker strips as well as door gaskets. All interior fittings are removable without tools to facilitate cleaning.

Adjusting the Shelves

For shelves mounted on pins, first select the desired location and remove the white plastic covers in the interior back and sides by rotating them counterclockwise. Remove the shelf pins by rotating them counterclockwise. Install the pins in the desired location by rotating clockwise. Make sure the pin is securely tightened. Do not over tighten. Slide the shelf into its new position and replace the white plastic covers into the holes vacated by the shelf pins.

Replacing the Light Bulb

All Traulsen R-Series models are supplied with LED lighting. Optional tube style display lighting is available.

The standard LED bar is 115 or 230 volts. It is mounted at the top front of the cabinet at the center.

To replace the light bar, remove the screws holding the brackets, replace the LED and place the LED on its original position on the cabinet top and re-mount the plastic brackets in the original position.

VI. Control Basics

Display

Your new Traulsen refrigerator, freezer or hot food cabinet is equipped with a multi-patented Smart Control™, which precisely regulates operation and provides critical alarms if problems occur. It is supplied from the factory ready to use and requires no adjustment (except hot food units which are set in the "OFF" position).



figure 11

On the left side of the display, there are four icons that reflect the status of the compressor, fans, defrost and alarms. At the center of the display is text that shows the cabinet temperature (see figure 11). It will also be used to access the control settings. Below the display are five tactile buttons used to access the control menu system.

Status Symbols

SYMBOL	DESCRIPTION
	Unlock
	Compressor / Heater Status
	Fan Status
	Defrost Status
	Alarm / Door Open

Button Symbols

SYMBOL	DESCRIPTION
	Display / Enter
	Unlock / Modify
	Plus (+) / Next
	Minus (-) / Previous
	Escape / Back / Cancel

NOTE: While accessing the control menu, text messages will be displayed. For example, the text displayed in figure 12 below is denoted as follows "SEn" (submenu).



figure 12

Changing the Setpoint

The setpoint of the unit can be changed by following the steps below:

1. Unlock the keypad by pressing the Unlock / Modify key "O" twice in succession.
2. While the cabinet temperature is displayed (home screen), press the Display / Enter Key "↵". "SEn" will display.
3. Push the Plus (+) or Minus (-) key to navigate the submenu until "SEt" displays.
4. Push the Display / Enter "↵" key. "000" will display.
5. Push the Display / Enter "↵" key two times to view the setpoint.
6. Push and hold the Unlock / Modify key. The control will now enter edit mode.
7. Push the Plus (+) or Minus (-) key to change the setpoint to the desired temperature.
8. Push the Display / Enter "↵" key once to register the new value.
9. Push the Display / Enter "↵" key again to confirm the change. The new setpoint will now display.
10. Push the Escape /Back / Cancel key "X" twice to exit the submenu system. The cabinet temperature will display.

Initiating a Defrost

All Traulsen units are designed to defrost automatically. If necessary, the user may manually initiate a defrost:

1. Unlock the keypad by pressing the Unlock / Modify key "O" twice in succession.
2. While the cabinet temperature is displayed (home screen), press the Display / Enter Key "↵". "SEn" will display.
3. Push the Plus (+) or Minus (-) key to navigate the submenu system until "SdF" displays.
4. Push the Display / Enter Key "↵" twice to start a defrost. Display will return to the home screen and the defrost icon should light up (see figure 13). The unit will terminate the defrost automatically without user intervention.

Changing the Defrost Interval

1. Unlock the keypad by pressing the Unlock / Modify key "O" twice in succession.
2. While the cabinet temperature is displayed (home screen), press the Display / Enter Key "↵". "SEn" will display.
3. Push the Plus (+) or Minus (-) key to navigate the submenu system until "SEt" displays.
4. Push the Display / Enter "↵" key. "000" will display.
5. Push the Plus (+) or Minus (-) key to set the first number to 5, then push the Display / Enter "↵" key.
6. Push the Plus (+) or Minus (-) key to set the second number to 5, then push the Display / Enter "↵" key.
7. Push the Plus (+) or Minus (-) key to set the third number to 5, then push the Display / Enter "↵" key. (The password is 555).
8. Push the Display / Enter Key "↵" again to enter the settings submenu. "SP" will display.
9. Push the Plus (+) or Minus (-) key to navigate the settings submenu until "di" displays.
10. Push the Unlock / Modify key "O". The control will now enter edit mode. The "hh" hour digits will start blinking.
11. Push the Plus (+) or Minus (-) key to adjust the "hh" digit and push the Display / Enter Key "↵" once to register the new value.
12. The "mm" (minute) digits will now start blinking. Push the Plus (+) or Minus (-) key to adjust the "mm" digit and push the Display / Enter Key "↵" once to register the new value.
13. The "ss" (seconds) digits will now start blinking. Push the Plus (+) or Minus (-) key to adjust the "ss" digit and push the Display / Enter Key "↵" once to register the new value.
14. Push the Display / Enter Key "↵" again to confirm the change. The new setting will now display.
15. Push the Escape /Back / Cancel key "X" twice to exit the submenu system.



figure 13

Accessing the Power Failure Data

1. Unlock the keypad by pressing the Unlock / Modify key "O" twice in succession.
2. While the cabinet temperature is displayed (home screen), press the Display / Enter Key "↵". "SEn" will display.
3. Push the Plus (+) or Minus (-) key to navigate the submenu system until "Al" displays.
4. Push the Display / Enter Key "↵" to navigate the alarm menu board.
5. Push the Plus (+) or Minus (-) key to navigate to parameter "tPd". The user will see the time duration the unit was powered down by pressing and holding the Display / Enter Key "↵".
6. Push the Plus (+) or Minus (-) key to navigate to parameter "tCu". The user will view the temperature recorded at the moment power was restored to the unit. This will be the warmest temperature during a power loss event.
7. To clear the alarm, push the Display / Enter Key "↵" again and use the Plus (+) or Minus (-) key to navigate to parameter "PFA". The parameter will display "Al". Push the Display / Enter Key "↵" twice to clear the alarm so that parameter displays "nor".
8. Push the Escape /Back / Cancel key "X" twice to exit the submenu system.

NOTE: You can use the Plus (+) or Minus (-) key in a similar fashion to review the status of other alarms while on step 5. For a list of alarms and other parameters please see the "Parameter Quick Reference Chart" in the following sections.

Turning the Unit ON/OFF (Hot Food Units Only)

To turn OFF the hot food unit, press the Escape /Back / Cancel key "X" until nothing is displayed on the screen. Push any key to turn the unit back ON.

Changing Fahrenheit to Celsius

1. Unlock the keypad by pressing the Unlock / Modify key "O" twice in succession.
2. While the cabinet temperature is displayed (home screen), press the Display / Enter Key "↵". "SEn" will display.
3. Push the Plus (+) or Minus (-) key to navigate the submenu system until "SEt" displays.
4. Push the Display / Enter "↵" key. "000" will display.
5. Push the Plus (+) or Minus (-) key to set the first number to 5, then push the Display / Enter "↵" key.
6. Push the Plus (+) or Minus (-) key to set the second number to 5, then push the Display / Enter "↵" key.
7. Push the Plus (+) or Minus (-) key to set the third number to 5, then push the Display / Enter "↵" key. (The password is 555).
8. Push the Display / Enter Key "↵" again to enter the settings submenu. "SP" will display.
9. Push the Plus (+) or Minus (-) key to navigate the settings submenu until "tun" displays.
10. Push the Unlock / Modify key "O". The control will now enter edit mode.
11. Push the Plus (+) or Minus (-) key to select "F" for Fahrenheit or "C" for Celsius and push the Display / Enter Key "↵" once to register the new value.
12. Push the Display / Enter Key "↵" again to confirm the change.
13. Push the Escape /Back / Cancel key "X" twice to exit the submenu system.

Parameter Quick Reference Chart

	PARAMETER	SUBMENU	PASSWORD	DATA
COMMONLY REFERENCED	SP	Sensor Readings	N/A	Cabinet Temperature
	tE	Sensor Readings	N/A	Evaporator Coil Temperature
	tLi	Sensor Readings	N/A	Liquid Line Temperature
	SP	Settings	555	Temperature Setpoint
	SPd	Settings	555	Cabinet Temperature Differential
	Fno	Settings	555	Fan Mode
	dSP	Settings	555	Defrost Setpoint
	dFo	Settings	555	Defrost Mode
	di	Settings	555	Interval Between Defrosts
	SEr	Settings	555	EOL: Serial Number
ALARMS	tCu	Alarms	N/A	Cabinet Temperature at Power Return
	tPd	Alarms	N/A	Time of Power Failure
	tPu	Alarms	N/A	Time of Power Return
	PFd	Alarms	N/A	Duration of Power Failure
	PFA	Alarms	N/A	Power Failure Alarm Status - "Alarm" = Power Failure - "Normal" = Alarm Has Been Cleared
	tCA	Alarms	N/A	Cabinet Temperature Alarm Status

VII. Troubleshooting Guide

PROBLEM	REMEDY
1. Condensing unit fails to start.	a. Has the cord and plug has been disconnected? Reconnect. b. Check control temperature setting.
2. Condensing unit operates for prolonged periods or continuously.	a. Are doors open? Shut completely. b. Is the condenser coil clean? Clean properly. c. Is the evaporator coil frozen? Initiate defrost.
3. Food compartment is too warm.	a. Check doors and gaskets for proper alignment and seal. b. Has a large quantity of warm food recently been added, or was the door kept open for a long period of time? In both cases allow adequate time for the cabinet to recover its normal operating temperature. c. Is the setpoint too high? Readjust setpoint. d. Is the condenser coil clean? Clean properly. e. Is product properly loaded into the unit? Be sure to allow proper airflow.
4. Food compartment is too cold.	a. Has a large quantity of very cold or frozen food recently been added? Allow adequate time for the cabinet to recover its normal operating temperature. b. Is the setpoint too low? Readjust the setpoint.
5. Condensation on the exterior surface.	a. Check doors and gaskets for proper alignment and seal. b. Depending on amount, condensation could be normal if unit is in a high-humidity environment.
6. Compressor hums but does not start.	a. Call for service.
7. Door open icon continually illuminated.	a. Are doors open? Shut completely. b. The door switch could be faulty. Replace the door switch.
8. Door open icon does not illuminate.	a. The door switch is faulty. Replace the door switch.
9. Evaporator fans not operating.	a. A defrost cycle is in progress (freezers only). b. If defrost is not in progress, call for service.
10. No power to unit.	a. Has the cord and plug has been disconnected? Reconnect. b. If cord and plug is connected, check power supply breaker.

VIII. Service & Warranty

Information

Before calling for service, please check the following:

- Is the electrical cord plugged in? **NOTE:** If the SUPPLY CORD is damaged, it must be replaced by the manufacturer, its service agent, or similarly qualified persons in order to avoid a possible electrical hazard.
- Is the fuse OK or circuit breaker on?
- Is the condenser coil clean?
- Is the power switch on?

If after checking the above items and the unit is still not operating properly, please contact an authorized Traulsen service agent: 4401 Blue Mound Road Fort Worth, TX 76106 | (800) 825-8220. Traulsen reserves the right to change specifications or discontinue models without notice.



NOTE: The ISO 7010-W021 symbol is a standardized safety sign used internationally to indicate a potential fire hazard. It features a black flame icon on a triangular yellow background with a black border, following ISO guidelines for warning symbols. This appliance is marked with the ISO 7010-W021 warning label to indicate the presence of **FLAMMABLE REFRIGERANTS**. Prior to beginning work on systems containing **FLAMMABLE REFRIGERANTS**, safety checks are necessary to ensure that the risk of ignition is minimized.

Ventilated Area

Ensure that the area is in the open or that it is adequately ventilated before breaking into the system or conducting any hot work. A degree of ventilation shall continue during the period that the work is carried out. The ventilation should safely disperse any released refrigerant and preferably expel it externally into the atmosphere.

Cabling

Check that cabling will not be subject to wear, corrosion, excessive pressure, vibration, sharp edges, or any other adverse environmental effects. The check shall also take into account the effects of aging or continual vibration from sources such as compressors or fans.

Detection of Flammable Refrigerants

Under no circumstances shall potential sources of ignition be used in the searching for or detection of refrigerant leaks. A halide torch (or any other detector using a naked flame) shall not be used.

The following leak detection methods are deemed acceptable for all refrigerant systems. Electronic leak detectors may be used to detect refrigerant leaks but, in the case of FLAMMABLE REFRIGERANTS, the sensitivity might not be adequate, or might need recalibration. (Detection equipment shall be calibrated in a refrigerant-free area.) Ensure that the detector is not a potential source of ignition and is suitable for the refrigerant used. Leak detection equipment shall be set at a percentage of the LFL of the refrigerant and shall be calibrated to the refrigerant employed, and the appropriate percentage of gas (25 % maximum) is confirmed.

Leak detection fluids are also suitable for use with most refrigerants but the use of detergents containing chlorine shall be avoided as the chlorine can react with the refrigerant and corrode the copper pipe-work.

NOTE: Examples of leak detection fluids are

- bubble method
- fluorescent method agents

If a leak is suspected, all naked flames shall be removed/extinguished.

If a leakage of refrigerant is found which requires brazing, all of the refrigerant shall be recovered from the system, or isolated (by means of shut off valves) in a part of the system remote from the leak. Removal of refrigerant shall be according to the removal & evacuation section below.

Removal & Evacuation

When breaking into the refrigerant circuit to make repairs- or for any other purpose - conventional procedures shall be used. However, for flammable refrigerants it is important that best practice be followed, since flammability is a consideration. The following procedure shall be adhered to:

- a) safely remove refrigerant following local and national regulations;
- b) purge the circuit with inert gas;
- c) evacuate
- d) purge with inert gas;
- e) open the circuit by cutting or brazing.

The refrigerant charge shall be recovered into the correct recovery cylinders if venting is not allowed by local and national codes. For appliances containing flammable refrigerants, the system shall be purged with oxygen- free nitrogen to render the appliance safe for flammable refrigerants. This process might need to be repeated several times. Compressed air or oxygen shall not be used for purging refrigerant systems .

For appliances containing flammable refrigerants, refrigerants purging shall be achieved by breaking the vacuum in the system with oxygen-free nitrogen and continuing to fill until the working pressure is achieved, then venting to atmosphere, and finally pulling down to a vacuum. This process shall be repeated until no refrigerant is within the system (optional for A2L). When the final oxygen-free nitrogen charge is used, the system shall be vented down to atmospheric pressure to enable work to take place.

Ensure that the outlet for the vacuum pump is not close to any potential ignition sources and that ventilation is available.

Spare Parts Information

To purchase replacement parts or to speak to service support for Traulsen units please contact our Ft. Worth facility by phone at 800-825-8220 or fax to 817-740-6748 (parts) or 817-740-6757 (service).

NOTE: When calling for spare parts or service support, please make sure you have model and serial number of unit available.

		ITW Food Equipment Group, LLC North American Refrigeration 4401 Blue Mound Rd. Ft. Worth, TX 76106 800-825-8220	
MODEL: MODELO: MODELE:	RDT232WUT-FHS ← Model Number		
SERIAL NUMBER:	25F ← Serial Number	SCAN FOR SERVICE INFO	
REFRIGERANT / REFRIGERANTE / RÉFRIGÉRANT			
SYS1 (REFM):	R-290	3.80 OZ	107.71 g 107,71 g
Hi Press. (PRESH):		360.00 psi	2,482.11 kPa 2,482,11 kPa
Lo Press. (PRESL):		130.00 psi	896.32 kPa 896,32 kPa
SYS2 (REFA):	R-290	3.00 OZ	85.04 g 85,04 g
Hi Press. (PRESH):		460.00 psi	3,171.59 kPa 3,171,59 kPa
Lo Press. (PRESL):		140.00 psi	965.27 kPa 965,27 kPa
Input Power (EUN) - FOR INDOOR USE ONLY			
Voltage		Hertz	Phase Total Amps
115 ~		60	1 12.60
Device/Part Number:		Device/Part Notes:	
COMPONENTS / COMPOSANTS / COMPONENTES			
	1	2	MAX OVER CURRENT PROTECTION (A):
COMP AMPS:			MIN CIRCUIT IN AMPS:
COND FAN AMPS:			DOME LIGHT WATTS: 11
EVAP FAN AMPS:			DISPLAY LIGHT WATTS:
CONTROL AMPS:			DOOR HEATER WATTS:
DEF HEATER WATTS:			B/TMCE HTR WATTS:
370-60297-00 REV. D 01/15/2024			

Warranty Registration

The warranties for your new Traulsen unit may be registered with us by completing warranty information online, via our website www.Traulsen.com. Click on the Warranty Registration text of the Service tab at the top of the home page. You may also register your product by calling us directly at 800-825-8220.

4401 Blue Mound Road Fort Worth, Texas 76106 (USA)
Phone: 800.825.8220 | Service Fax: 817.740.6757 | E-mail: service@traulsen.com | Website: traulsen.com

Form Number: TR35743 | Part Number: 375-60311-00 | Revision Date: 04/2026
Traulsen © All Rights Reserved