

Project	Quantity	Item #
Model Specified:		CSI Section 11400

Roll-Thru Double Depth Refrigerator Models/Self-Contained



Model RRI264LPUT-FHS

Two & Three Section Roll-Thru Models - 64" Deep



Stainless Exterior
& Interior

2-Section Refrigerator Model
3-Section Refrigerator Model

RRI264LPUT-FHS
RRI364LPUT-FHS

The R-Series "L-Height" Roll-Thru Double Depth Refrigerator line is designed to offer storage capacity and easy access for 66" high racks. They are supplied standard with all the Traulsen top of the line features, such as balanced refrigeration systems, next generation INTELA-TRAUL® controls and stainless steel exteriors. Additionally, they offer the widest range of optional accessories, and can be modified for many applications, such as: correctional, export, etc. Racks are not supplied by Traulsen.

Standard Product Features

- Stainless Steel Exterior & Interior
- INTELA-TRAUL® Microprocessor Control System
- Balanced, Self-Contained Refrigeration System Using R-134A Refrigerant
- Full Length Stainless Steel Doors With Locks
- Self-Closing Doors With Stay Open Feature At 120 Degrees
- Guaranteed For Life Cam-Lift Hinges
- Guaranteed For Life Horizontal Work Flow Door Handle
- Standard Door Hinging: 232LP = F & R: Left/Right, 332LP = F & R: Left/Right/Right (other hings available)
- Automatically Activated Incandescent Lights
- Stainless Steel Breaker Caps
- Accommodates Roll-In Racks Up To 66" High (provided by others)
- Automatic Non-Electric Condensate Evaporator
- Magnetic Snap-In EZ-Clean Door Gasket(s)
- Gasket-Protecting Metal Door Liner
- Stainless Steel Interior Rack Guides
- Stainless Steel Threshold Ramps
- Controllable Anti-Condensate Door Perimeter Heaters
- Thermostatic Expansion Valve Metering Device
- Stainless Steel One-Piece Louver Assembly
- Three Year Parts And Labor Warranty
- Five Year Compressor Warranty

Options & Accessories

- Stainless Steel Finished Back With Rear Louvers
- Re-Hinging Feature For Doors
- Wire Shelf Package For Roll-In Model (includes three shelves per section)
- Additional Wire Shelves For Above
- Stainless Steel Shelf Package For Roll-In Model (includes three shelves per section)
- Additional Stainless Steel Shelves For Above
- Locking Hasps (padlocks supplied by others)
- Kool Klad Exterior Laminate Decor
- Prison/Correctional Facilities Options
- Remote Applications (see spec sheet TR35837 for more details)
- Remote Monitoring (monitoring supplied by E-Control)



Approval: _____



TRAULSEN
4401 BLUE MOUND RD.
PHONE 1 (800) 825-8220
Website: www.traulsen.com

FT. WORTH, TX 76106
FAX-MKTG. 1 (817) 624-4302

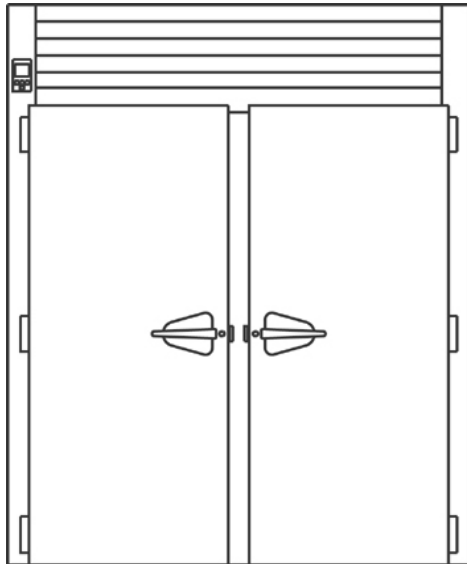

RRI264LPUT Front View

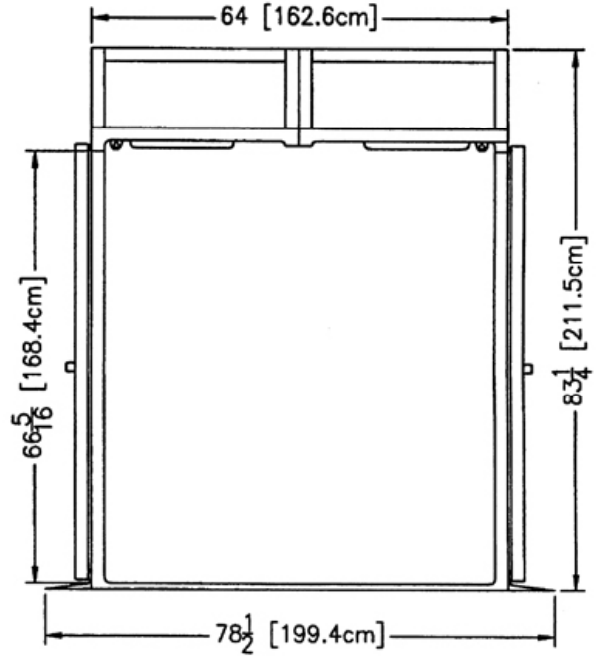

RRI264LPUT Side View

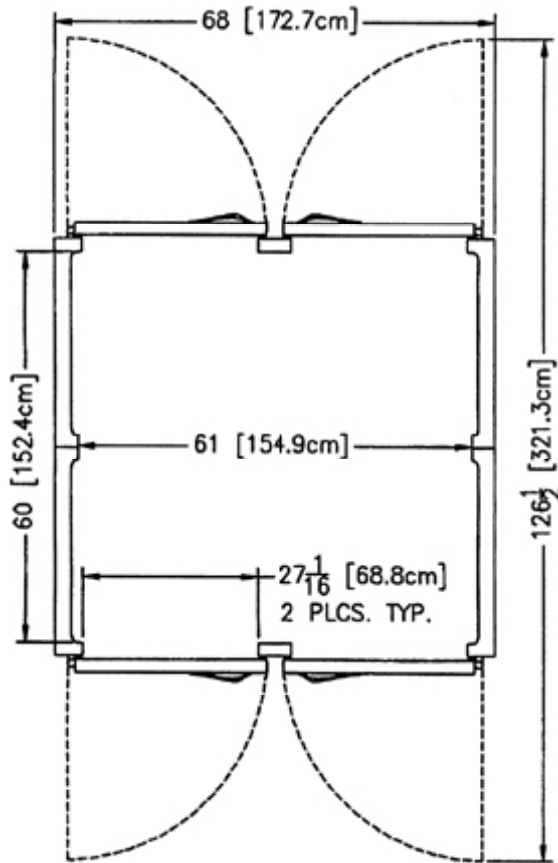

RRI264LPUT Top View

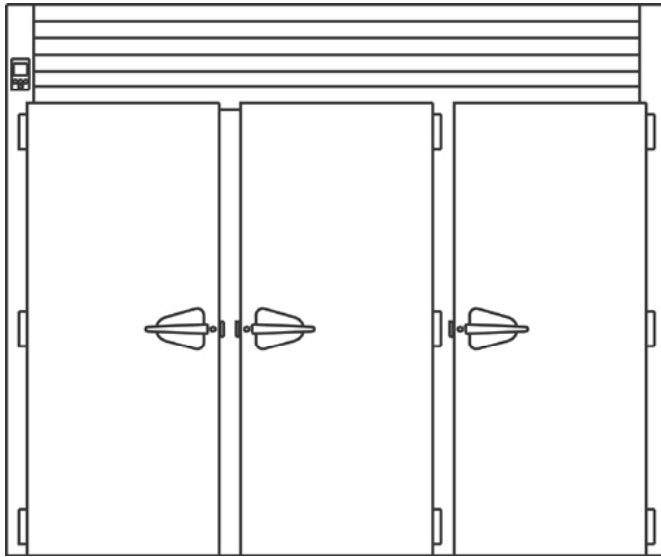

RRI364LPUT Front View

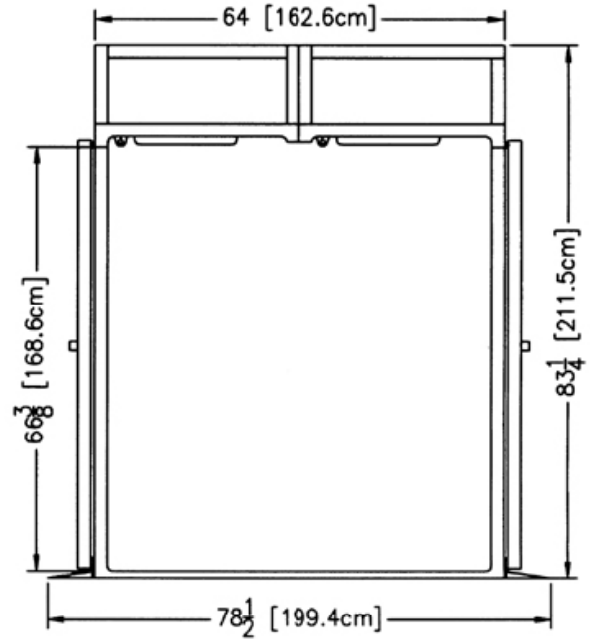

RRI364LPUT Side View

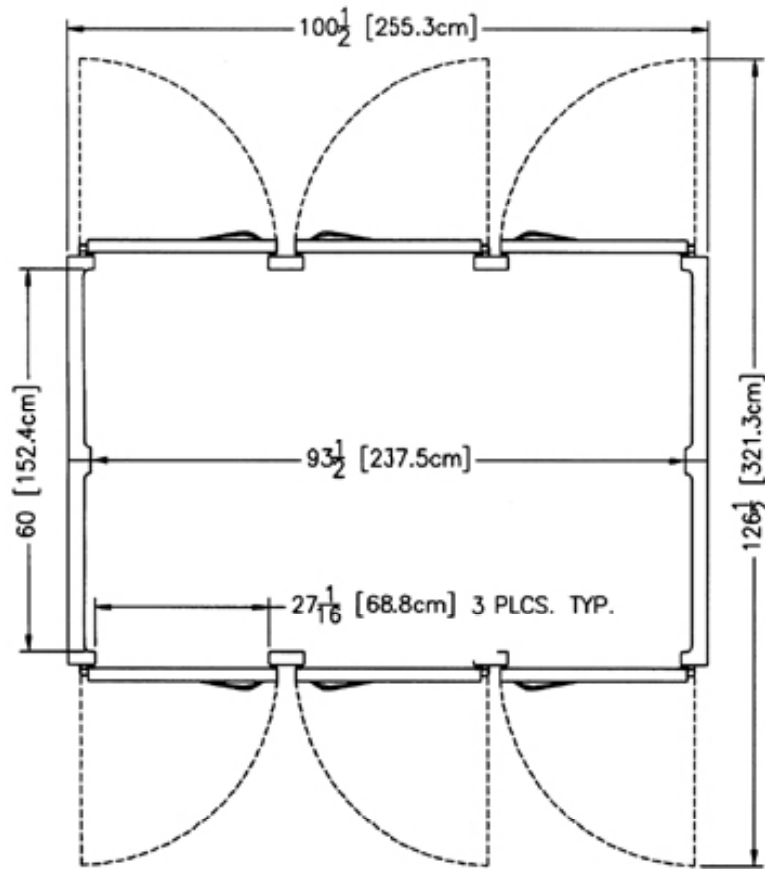

RRI364LPUT Top View



TRAUlsen
 4401 BLUE MOUND RD.
 PHONE 1 (800) 825-8220
 Website: www.traulsen.com

FT. WORTH, TX 76106
 FAX-MKTG. 1 (817) 624-4302

Project	Quantity	Item #
Model Specified:		CSI Section 11400

Specifications

Construction, Hardware and Insulation

Cabinet exterior, including front, one piece sides, louver assembly and doors are constructed of heavy gauge stainless steel. Cabinet interior and door liners are constructed of stainless steel. Exterior cabinet top and bottom are constructed of heavy gauge aluminized steel. The interior floor is constructed of stainless steel and insulated with ¾" of resilient cork. A readily attachable stainless steel ramp is provided.

Doors are equipped with heavy-duty, extruded wiper gasket for sealing to bottom ramp, removable plug cylinder locks and guaranteed for life cam-lift, gravity action, self-closing metal, glide hinges with stay open feature at 120 degrees. Hinges include a switch to automatically activate the interior incandescent lighting. Guaranteed for life, work flow door handle is mounted horizontally over recess in door which limits protrusion from door face into aiseways.

Gasket profile and Santoprene® material simplify cleaning and increase overall gasket life. Anti condensate heaters are located behind each door opening.

Cabinet and door contains high density, non-CFC, foamed in place polyurethane insulation.

Refrigeration System

A top mounted, self-contained, balanced refrigeration system using R-134a refrigerant is conveniently located behind the one piece louver assembly. It features a plenum effect blower coil, large, high humidity evaporator coil located outside the food zone, and a top mounted non-electric condensate evaporator. Standard operating temperature is 36 to 38°F.

Controller

The easy to use water resistant INTELA-TRAUL® microprocessor control system is supplied standard. RS485 data port enables data communications for remote monitoring such as NAFEM Data Protocol, E-Control Systems® and others. It includes a 3-Digit LED Display and Fahrenheit or Celsius Temperature Scale Display Capability. In addition it includes audio/visual alarms for: Hi/Lo Cabinet Temperature, Door Open, Clean Condenser, Evaporator Coil and Discharge Line Sensor Failures, and Power Supply Interruption.

Interior

Readily removable, interior-mounted, stainless steel guides for rack are provided for protection. Maximum rack size with wheels inboard of frame is 27" wide by 29" deep by 66" high. Racks supplied by others.

Warranties

Both a three year parts and labor warranty and a five year compressor warranty (self-contained models only) are provided standard.

DIMENSIONAL DATA	RRI264LPUT	RRI364LPUT
Net capacity cu. ft.	160.4 (4544 cu l)	243.0 (6884 cu l)
Length - overall in.	68 (172.7 cm)	100½ (255.3 cm)
Depth - overall in.	71½ (180.6 cm)	71½ (180.6 cm)
Depth - over body in.	64 (162.6 cm)	64 (162.6 cm)
Depth - with door open 90 degrees in.	126½ (321.3 cm)	126½ (321.3 cm)
Clear door width in.	27⅙ (68.8 cm)	27⅙ (68.8 cm)
Clear door height in.	66⅞ (168.4 cm)	66⅞ (168.6 cm)
Height - overall in. ⁵	83¼ (211.5 cm)	83¼ (211.5 cm)
Rack Capacity	4	6
Net Wt. lbs.	775 (352 kg)	1050 (476 kg)
ELECTRICAL DATA		
Voltage	208-230/115/60/1	208-230/115/60/1
Feed wires with Ground	4	4
Full load amperes	15.0	15.6
Wattage ¹	2157	2447
REFRIGERATION DATA		
Refrigerant	R-134a	R-134a
BTU/HR H.P. ²	8400 (2 x ½ HP)	10240 (2 x ¾ HP)

NOTES

NOTE: Figures in parentheses reflect metric equivalents.

1= Based on a 90 degree F ambient and 20 degree F evaporator.

2= Wattage is determined by listed amps X listed volts X an average run time of 70% for refrigerators and 80% for freezers.

3= For approximate remote weights deduct 40 lbs. from respective net or gross weight. For other information on remote models, please refer to spec sheet TR35837.

4= Shipped in two cartons for assembly at job site. For total shipping weight, double figure shown.

5= 12" Top clearance preferred for optimum performance and service access.

NOTE: When ordering please specify: Voltage, Hinging, Door Size, Options and any additional warranties.

Continued product development may necessitate specification changes without notice.

Part No. TR35809 (REV. 02-19-14)

TRAULSEN
4401 BLUE MOUND RD.
PHONE 1 (800) 825-8220
Website: www.traulsen.com

FT. WORTH, TX 76106
FAX-MKTG. 1 (817) 624-4302

