



Instructions for the installation, use and care of:  
*R-Series / G-Series*  
*TE-Series / TU-Series / TS-Series*

## Quick Start Guide

### Receipt & Support Installation

You should carefully inspect your Traulsen unit for damage during delivery. If damage is detected, you should save all the crating materials and make note on the carrier's Bill Of Lading describing the damage. A freight claim should be filed within 5 days.

After uncrating the unit, select a level location for final placement. Install the casters (or optional leg supports) as shown below.

**Supports:** "Plate" casters (Standard for G), "Stem" type legs (Standard for R), "Channel" type casters (Standard for TE, TU, TS)

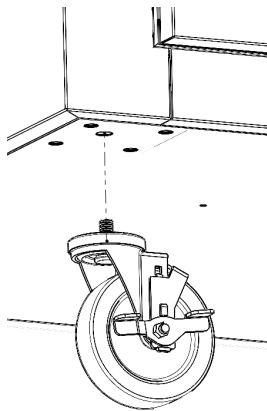

Stem Type Caster

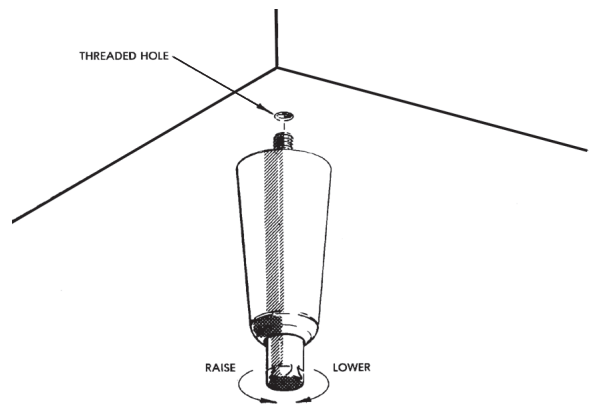

Stem Type Leg

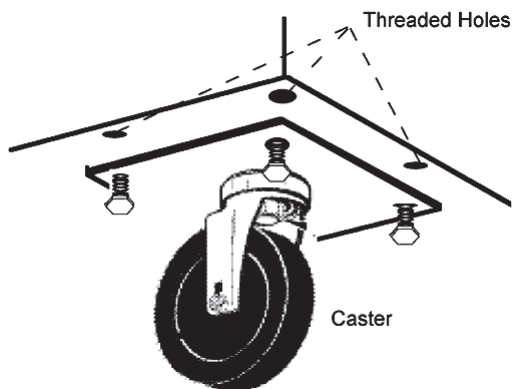
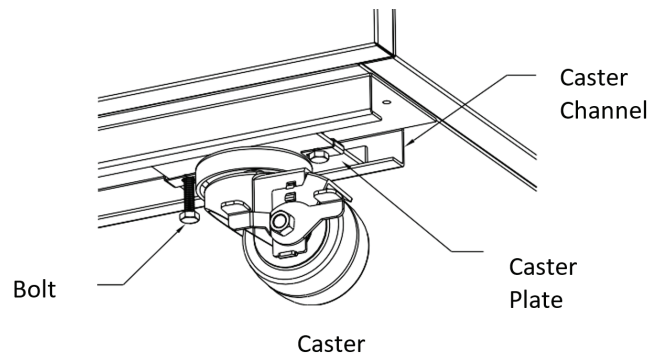

Plate Type Caster



Channel Caster

**⚠ WARNING**

Traulsen models may use R-290 (Propane) as a refrigerant. If flammable refrigerant is present, follow instructions as labeled on the unit. Proper care must be taken to avoid any damage to refrigeration system including refrigerant tubing, condenser, evaporator coils during handling, moving, installation and cleaning as it may cause risk of fire or explosion. If damaged, unit must be moved to well ventilated area away from any sources of ignition.

Further service and repair must be performed by qualified refrigeration technicians familiar with applicable safety standards for flammable refrigerants. Technicians must use appropriate personal protective equipment and follow applicable safety precautions to avoid risk of fire or explosion.

Upright models should be installed to allow at least 12" of clear space above the unit. In all cases, the louvers must be free of any obstruction which could prevent proper airflow.

Most units are supplied with a cord and plug, which can simply be plugged into a dedicated appropriately sized outlet. For those requiring hard-wiring directly to the power supply, this should be done by a qualified electrician only.

**NOTE:** Some models require provision of a bottom mounted condensate evaporator. Follow instructions provided with part, along with the figure below for installation.

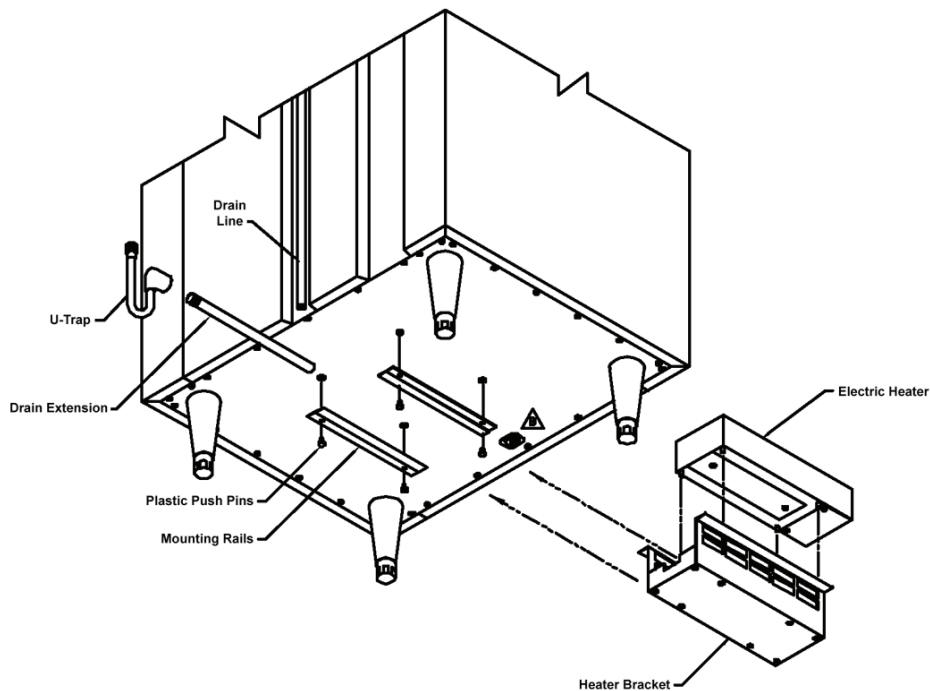

**Bottom Mounted Condensate Evaporator**

## Uprights Control Overview

Most Traulsen equipment is plug and play. However, once power is supplied to the unit, you may make minor adjustments to your Traulsen unit.



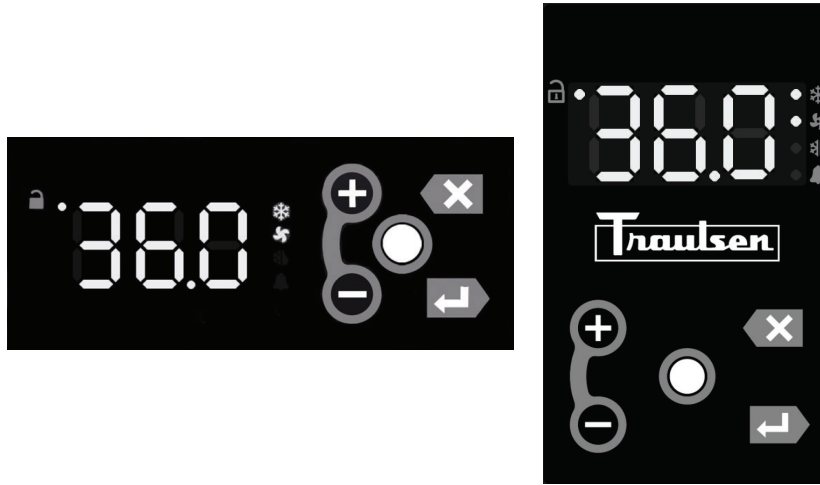

**NOTE:** Can be horizontal or vertical.







## Understanding the Uprights Display

On the left or top portion of the display there are colored LEDs for showing the temperature, compressor status, fans, whether the control is locked/unlocked, etc.

On the right or bottom portion of the display there are five tactile buttons that manage the operation of the unit.

LED SYMBOL	DESCRIPTION
	Unlock
	Compressor / Heater Status
	Fan Status
	Defrost Status
	Alarm / Door Open

BUTTON SYMBOL	DESCRIPTION
	Display / Enter
	Unlock / Modify
	Plus (+) / Next
	Minus (-) / Previous
	Escape / Back / Cancel

## Unlocking the Keypad

Normally, the keypad is locked to prevent inadvertent changes to settings. The unlock key is a white dot on the right or bottom portion of the display, centered between the other four buttons. Press the unlock key twice within a second in order to unlock the keypad (think “tap-tap”). The **unlock** LED will illuminate to indicate the keypad is live. The keypad will stay unlocked until three minutes of inactivity have passed, at which time it will automatically lock the keypad. There are two operations the user can perform without having to enter a password: change the temperature setpoint, initiate a defrost operation, or turn the heaters off if unit is a hot food cabinet.

## Changing the Temperature Setpoint

The setpoint to the unit can be changed simply by pressing the Plus (+) or Minus (-) key. There will be a slight delay at first to prevent an accidental change, so it will be necessary to hold the key for three-four seconds until the value starts to flash. The flashing value indicates the setpoint is being modified. To raise the setpoint, press the Plus (+) key to increment to the setpoint you want. Similarly, press the Minus (-) key to lower the setpoint. When the desired value is reached, press the Enter / Display “↵” key to lock in the value. Pressing the Escape / Back / Cancel key “X” will abort the process and keep the original setpoint. The keypad must be unlocked in order to change the setpoint using the shortcut method.

## Initiating a Defrost Operation

UNIT	DEFROST INTERVAL
Upright Ref	8 hours
Upright Frz	4 hours
Horizontals	6 hours

Defrost is a necessary operation to remove frost that builds up on the evaporator coil and reduces airflow within the cabinet. Normally this is done automatically based on a time interval and the ambient conditions of the environment. A special sensor is used to measure the humidity in the air to adjust the defrost interval depending upon humidity levels. The nominal defrost intervals are shown in the table on the left.

To manually defrost the unit, press the Minus (-) key and the Escape /Back / Cancel key "X" simultaneously and hold for five seconds. Units equipped with and LED temperature display will indicate when a defrost cycle is in progress. The **defrost** LED will illuminate to indicate that a defrost operation is in progress. Depending on the settings, the display may show "dEF".

## Turning the Heaters Off - Hot Food Cabinets

The keypad must be unlocked in order to deactivate the heaters. Press the unlock key twice within a second in order to unlock the keypad (think "tap-tap"). The **unlock** LED will illuminate to indicate the keypad is live. To turn the unit off, press and hold the unlock key until the display shows "OFF". To turn the unit on, press the unlock key until the display shows the cabinet temperature.

## Horizontals Control Overview





Most Traulsen equipment is plug and play. However, once power is supplied to the unit, you may make minor adjustments to your Traulsen unit.







## Understanding the Horizontals Display

To the left and right of the display screen there are colored LEDs for showing the temperature, fans, defrost, etc.

On bottom portion of the display there are four push buttons that manage the operation of the unit.

LED SYMBOL	DESCRIPTION
	Thermostat Output
	Fan Status
	Defrost Status
	Activation of 2 <sup>nd</sup> Parameter Set
	Alarm

BUTTON SYMBOL	DESCRIPTION
	Parameter Menu
	Defrost Operation / Decrease
	Manual Activation / Increase
	Exit / Stand By

## Information Menu

The information available in this menu is: Instant Probe 1 Temperature “t1”, Instant Probe 2 Temperature “t2”\* and Compressor Working Weeks “cnd”\*\*.

\*Displayed only if enabled (see Configuration Parameters in the following sections)

\*\*Displayed only if ACC > 0

To access the menu and information press and immediately release the Parameter Menu “i” button. Navigate to the data you want to display with the Manual Activation / Increase “▲” or Defrost Operation / Decrease “▼” button. Press the Parameter Menu “i” button to display the value. To exit the menu, press the Exit / Stand By “X” button.

To initiate a stand by, press and hold the Exit / Stand By “⏻” button for three seconds. This allows the control to be put on stand by or the output control to be resumed (with **SB** = YES only).

## Locking the Keypad

The ability to lock the keypad helps to avoid undesired, potentially dangerous, operation which might be attempted when the controller is operating in a public place. In the Information Menu, set parameter **LOC** = YES to inhibit all functions of the buttons. To resume normal operation of the keypad, adjust the parameter to **LOC** = NO.

## Changing the Temperature Setpoint

To modify the temperature setpoint, Press the Parameter Menu “i” button for at least half a second to display the setpoint value. While keeping the Parameter Menu “i” button pressed, use the Manual Activation / Increase “▲” or Defrost Operation / Decrease “▼” button to set the desired value (adjustment is within the minimum **SPL** and the maximum **SPH** limit). When the Parameter Menu “i” button is released, the new value is stored.

## Initiating a Defrost Operation

Defrost starts automatically as soon as the time set with parameter **DFT** has elapsed.

- **Timed Defrost:** With **DFM** = TIM defrost takes place at regular intervals when the timer reaches the value of **DFT**. For example, with the factory set **DFM** = TIM and **DFT** = 36, a defrost operation will take place every six hours.
- **Adaptive Defrost:** With **DFM** = FRO the timer is only increased when the conditions occur for frost to form on the evaporator, until the time set with parameter **DFT** is matched. If the evaporator works at 0°F, defrost frequency depends on the thermal load and ambient conditions. With setpoints lower than 0°F defrost frequency mainly depends on the unit operating time.
- **Defrost Time Count Backup:** When operation resumes, if **DFB** = YES, the defrost timer resumes the time count from where it was left off before the operation disruption. When **DFB** = NO, the time count re-starts from zero. In stand by, the accumulated time count is frozen.

It's possible to manually start a defrost by pressing the Defrost Operation / Decrease “▼” button for two seconds. Once the defrost operation has started, the compressor and defrost outputs are controlled according to parameter **DTY**. If **FID** = YES, the evaporator fans are active during defrost. The actual defrost duration is influenced by a series of parameters.

- **Time Termination:** **T2** = NO and **T3** different from 2EU; the evaporator temperature is not monitored and defrost will last as long as time **DTO**.
- **Temperature Monitoring of Evaporator:** **T2** = YES and **T3** different from 2EU; the sensor **T2** measures the temperature **DLI** before the time **DTO** elapses. Defrost will be terminated in advance.

When the defrost operation ends, the thermostatic cycle resumes if **DRN** is greater than zero. All outputs will remain off for **DRN** minutes, in order for the ice on the evaporator coil to melt completely and the resulting water to drain. Moreover, if probe **T2** = YES, the fans will re-start when the evaporator gets to a temperature lower than **FDD**. Vice versa, if probe **T2** = NO or after the defrost operation has come to an end, such condition does not occur by the end of the time **FTO**, after **FTO** minutes have elapsed the fans will be switched on anyway. **CAUTION:** If **DFM** = NON or **C-H** = HEA all defrost functions are inhibited; if **DFT** = 0, automatic defrost operations are excluded.

## Configuration Parameters

To get access to the parameter configuration menu, press and hold the Exit / Standby “⏻” and the Parameter Menu “i” buttons simultaneously for five seconds. Press the Manual Activation / Increase “▲” or Defrost Operation / Decrease “▼” button to select the parameter to be modified. Press the Parameter Menu “i” button to display the value. Then press and hold the Parameter Menu “i” button while simultaneously pressing the Manual Activation / Increase “▲” or Defrost Operation / Decrease “▼” button to set the desired value. When the Parameter Menu “i” button is released, the newly programmed value is stored and the following parameter is displayed. To exit the parameter configuration menu, press the Exit / Standby “X” button or wait thirty seconds.

## Operation Display Indicators

During normal operation, the display shows either the temperature measured or one of the following indications:

- **dEF** = Defrost in progress
- **oFF** = Controller in stand by
- **cL** = Condenser clean warning
- **do** = Door open alarm
- **E1** = Probe T1 failure
- **E2** = Probe T2 failure
- **E3** = Probe T3 failure

## General Care

### **⚠ WARNING**

**Disconnect the electrical power supply before cleaning any part of the unit.** All Traulsen equipment should be cleaned only with warm water, mild soap and a soft cloth. Apply with a dampened cloth and wipe in the direction of the metal grain.

Avoid the use of strong detergents and gritty, abrasive cleaners as they may tend to mar and scratch the surface. Do NOT use cleansers containing chlorine- this may promote metal corrosion.

**Care should be taken to avoid splashing the unit with water,** containing chlorinated cleansers, when mopping the floor around the unit. For stubborn odor spills, use baking soda and water (mix 1 tablespoon baking soda : 1 pint water ratio).

## Adjusting the Shelves

*Shelves Mounted on Pins:* First select the desired location and remove the white plastic covers in the interior back and sides by rotating them counterclockwise. Remove the shelf pins by rotating them counterclockwise. Install the pins in the desired location by rotating clockwise. Make sure the pin is securely tightened. Do not over tighten. Slide the shelf into its new position and replace the white plastic covers into the holes vacated by the shelf pins.

*Shelves Mounted on Pilasters and Clips:* For each shelf, insert four shelf clips into the pilaster slots at the same height. The shelf clips have a small projection on top which holds the shelf in position and prevents it from slipping forward. After installing shelf clips on pilasters, place shelves on the clips.

## Operation Display Indicators

**Disconnect the electrical power supply before cleaning any part of the unit.** This is the single most important thing you can do to promote long, efficient equipment life. For all upright cabinets, remove the two bottom screws that secure the louver panel, then pivot this upward to allow full access to the front-facing condenser. For all horizontal cabinets, you will either gently pull to swing open (like a door) or gently lift up and out the louver panel off bracket of the unit (see next page).

Vacuum or brush any dirt, lint or dust from the condenser coil, around the compressor and other cooling system components as indicated. If significant dirt is clogging the condenser fins, use compressed air to blow this clear. When finished reverse the louver removal process as instructed above.

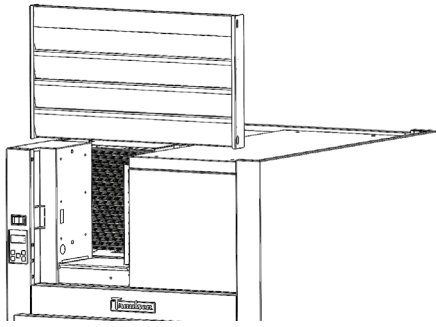

**R-Series & G-Series Cabinets**

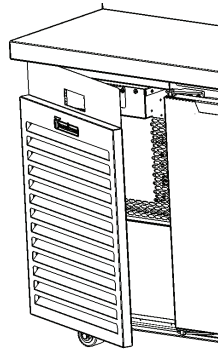

**TS-Series Cabinets**

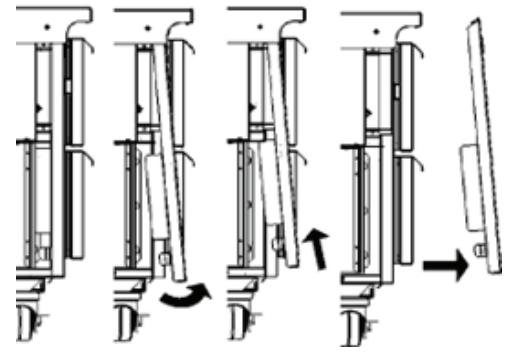

**TE-Series & TU-Series Cabinets**

## Troubleshooting Guide

### **⚠ WARNING**

Some models may use R-290 (Propane) as a refrigerant. Service and repair must be performed by qualified refrigeration technicians familiar with applicable safety standards for flammable refrigerants. Technicians must use appropriate personal protective equipment and follow applicable safety precautions to avoid risk of fire or explosion. Service and repair must be performed in well ventilated and unconfined area, away from any ignition sources. All system components must be replaced with like components. Factory recommends to use exact make and models to assure the consistent performance and to minimize the risk of possible ignition due to incorrect parts. In case of uncertainty or parts unavailability, contact Traulsen technical assistance at 800-825-8220.

<b>PROBLEM</b>	<b>REMEDY</b>
1. Condensing unit fails to start.	<ul style="list-style-type: none"> <li>a. Has the cord and plug has been disconnected? Reconnect.</li> <li>b. Check control temperature setting.</li> </ul>
2. Condensing unit operates for prolonged periods or continuously.	<ul style="list-style-type: none"> <li>a. Are doors open? Shut completely.</li> <li>b. Is the condenser coil clean? Clean properly.</li> <li>c. Is the evaporator coil frozen? Initiate defrost.</li> </ul>
3. Food compartment is too warm.	<ul style="list-style-type: none"> <li>a. Check doors and gaskets for proper alignment and seal.</li> <li>b. Has a large quantity of warm food recently been added, or was the door kept open for a long period of time? In both cases allow adequate time for the cabinet to recover its normal operating temperature.</li> <li>c. Is the setpoint too high? Readjust setpoint.</li> <li>d. Is the condenser coil clean? Clean properly.</li> <li>e. Is product properly loaded into the unit? Be sure to allow proper airflow.</li> </ul>
4. Food compartment is too cold.	<ul style="list-style-type: none"> <li>a. Has a large quantity of very cold or frozen food recently been added? Allow adequate time for the cabinet to recover its normal operating temperature.</li> <li>b. Is the setpoint too low? Readjust the setpoint.</li> </ul>
5. Condensation on the exterior surface.	<ul style="list-style-type: none"> <li>a. Check doors and gaskets for proper alignment and seal.</li> <li>b. Depending on amount, condensation could be normal if unit is in a high-humidity environment.</li> </ul>

## **Service & Warranty Information**

Before calling for service, please check the following:

- Is the electrical cord plugged in? **NOTE:** If the SUPPLY CORD is damaged, it must be replaced by the manufacturer, its service agent, or similarly qualified persons in order to avoid a possible electrical hazard.
- Is the fuse OK or circuit breaker on?
- Is the condenser coil clean?
- Is the power switch on?

If after checking the above items and the unit is still not operating properly, please contact an authorized Traulsen service agent: 4401 Blue Mound Road Fort Worth, TX 76106 | (800) 825-8220. Traulsen reserves the right to change specifications or discontinue models without notice.



**NOTE:** The ISO 7010-W021 symbol is a standardized safety sign used internationally to indicate a potential fire hazard. It features a black flame icon on a triangular yellow background with a black border, following ISO guidelines for warning symbols. This appliance is marked with the ISO 7010-W021 warning label to indicate the presence of **FLAMMABLE REFRIGERANTS**. Prior to beginning work on systems containing **FLAMMABLE REFRIGERANTS**, safety checks are necessary to ensure that the risk of ignition is minimized.

### **Ventilated Area**

Ensure that the area is in the open or that it is adequately ventilated before breaking into the system or conducting any hot work. A degree of ventilation shall continue during the period that the work is carried out. The ventilation should safely disperse any released refrigerant and preferably expel it externally into the atmosphere.

### **Cabling**

Check that cabling will not be subject to wear, corrosion, excessive pressure, vibration, sharp edges, or any other adverse environmental effects. The check shall also take into account the effects of aging or continual vibration from sources such as compressors or fans.

### **Detection of Flammable Refrigerants**

Under no circumstances shall potential sources of ignition be used in the searching for or detection of refrigerant leaks. A halide torch (or any other detector using a naked flame) shall not be used.

The following leak detection methods are deemed acceptable for all refrigerant systems. Electronic leak detectors may be used to detect refrigerant leaks but, in the case of FLAMMABLE REFRIGERANTS, the sensitivity might not be adequate, or might need recalibration. (Detection equipment shall be calibrated in a refrigerant-free area.) Ensure that the detector is not a potential source of ignition and is suitable for the refrigerant used. Leak detection equipment shall be set at a percentage of the LFL of the refrigerant and shall be calibrated to the refrigerant employed, and the appropriate percentage of gas (25 % maximum) is confirmed.

Leak detection fluids are also suitable for use with most refrigerants but the use of detergents containing chlorine shall be avoided as the chlorine can react with the refrigerant and corrode the copper pipe-work.

**NOTE:** Examples of leak detection fluids are

- bubble method
- fluorescent method agents

**If a leak is suspected, all naked flames shall be removed/extinguished.**

If a leakage of refrigerant is found which requires brazing, all of the refrigerant shall be recovered from the system, or isolated (by means of shut off valves) in a part of the system remote from the leak. Removal of refrigerant shall be according to the removal & evacuation section below.

## Removal & Evacuation

When breaking into the refrigerant circuit to make repairs- or for any other purpose - conventional procedures shall be used. However, for flammable refrigerants it is important that best practice be followed, since flammability is a consideration. The following procedure shall be adhered to:

- safely remove refrigerant following local and national regulations;
- purge the circuit with inert gas;
- evacuate
- purge with inert gas;
- open the circuit by cutting or brazing.

The refrigerant charge shall be recovered into the correct recovery cylinders if venting is not allowed by local and national codes. For appliances containing flammable refrigerants, the system shall be purged with oxygen- free nitrogen to render the appliance safe for flammable refrigerants. This process might need to be repeated several times. Compressed air or oxygen shall not be used for purging refrigerant systems .

For appliances containing flammable refrigerants, refrigerants purging shall be achieved by breaking the vacuum in the system with oxygen-free nitrogen and continuing to fill until the working pressure is achieved, then venting to atmosphere, and finally pulling down to a vacuum. This process shall be repeated until no refrigerant is within the system (optional for A2L). When the final oxygen-free nitrogen charge is used, the system shall be vented down to atmospheric pressure to enable work to take place.

Ensure that the outlet for the vacuum pump is not close to any potential ignition sources and that ventilation is available.







## Spare Parts Information

To purchase replacement parts or to speak to service support for Traulsen units please contact our Ft. Worth facility by phone at 800-825-8220 or fax to 817-740-6748 (parts) or 817-740-6757 (service).

**NOTE:** When calling for spare parts or service support, please make sure you have model and serial number of unit available.

## Warranty Registration

The warranties for your new Traulsen unit may be registered with us by completing warranty information online, via our website [www.Traulsen.com](http://www.Traulsen.com). Click on the Warranty Registration text of the Service tab at the top of the home page. You may also register your product by calling us directly at 800-825-8220.

				ITW Food Equipment Group, LLC North American Refrigeration 4401 Blue Mound Rd. Ft. Worth, TX 76106 800-825-8220			
MODEL:		RDT232WUT-FHS		← Model Number			
MODEL NO.:				← Serial Number			
MODEL:							
SERIAL NUMBER:		25F		←		SCAN FOR SERVICE INFO	
REFRIGERANT / REFRIGÉRANTE / RÉFRIGÉRANT							
SYS1 (REFM):		R-290	3.80 OZ	107.71 g	107,71 g		
Hi Press. (PRESH):			360.00 psi	2,482.11 kPa	2,482,11 kPa		
Lo Press. (PRESL):			130.00 psi	896.32 kPa	896,32 kPa		
SYS2 (REFA):		R-290	3.00 OZ	85.04 g	85,04 g		
Hi Press. (PRESH):			460.00 psi	3,171.59 kPa	3,171,59 kPa		
Lo Press. (PRESL):			140.00 psi	965.27 kPa	965,27 kPa		
Input Power (ELIN) - FOR INDOOR USE ONLY							
Voltage		Hertz		Phase		Total Amps	
115 ~		60		1		12.60	
Device/Part Number:				Device/Part Notes:			
 Intertek 4004142 <small>UL LISTED FOR REFRIGERATION</small>		 Intertek 4004142 <small>COMPONENTS LISTED FOR REFRIGERATION</small>					
 Intertek EP 5018173 <small>MARKED FOR REFRIGERATION</small>							
COMPONENTS / COMPOSANTS / COMPONENTES							
		1		2		MAX OVER CURRENT PROTECTION (A):	
COMP AMPS:						MIN CIRCUIT IN AMPS:	
COND FAN AMPS:						DOME LIGHT WATTS: 11	
EVAP FAN AMPS:						DISPLAY LIGHT WATTS:	
CONTROL AMPS:						DOOR HEATER WATTS:	
DEF HEATER WATTS:						B/TMCE HTR WATTS:	
370-60297-00 REV. D 01/15/2024							

Please visit our website [www.traulsen.com](http://www.traulsen.com) for additional literature or service/parts information. From our home page, select your product under the **PRODUCTS** tab or any of the following options under the **SERVICE & PARTS** tab:

- Warranty & Local Service
- Owner's Manuals
- Parts Pricing
- Service Manuals
- Warranty Registration

**HOURS OF OPERATION:**

**Monday thru Friday 7:30 AM - 6:30 PM CST**

Traulsen

4401 Blue Mound Road Fort Worth, TX 76106

Phone (800) 825-8220

Service Fax (817) 740 6757

[www.traulsen.com](http://www.traulsen.com)