



Project \_\_\_\_\_  
 AIA # \_\_\_\_\_ SIS # \_\_\_\_\_  
 Item # \_\_\_\_\_ Quantity \_\_\_\_\_ C.S.I. Section 114000



## HTs Scale



### SPECIFIER STATEMENT

HTs scales include a single-core processor and Linux operating system. HTs scales weigh, automatically compute a price from stored PLU's, and print a label. The HTs scales utilize Hobart's patented, two screen swipe technology user interface for operator ease of use. Scales on the same network may connect remotely to other scales for a HWS (Hand Wrap Station) or other applications.

### MODELS

Model	Customer Display	Weigher Capacity	Network
<input type="checkbox"/> HTs-LS	None	30 lb.	wired/wireless
<input type="checkbox"/> HTsP-LS	None	None	wired/wireless
<input type="checkbox"/> HTs-7LS	7"	30 lb.	wired/wireless
<input type="checkbox"/> HTs-7ELS	7" Elevated	30 lb.	wired/wireless

### STANDARD FEATURES

- + Video playback on operator display
- + Intuitive and customizable graphical user interface
- + Best seller keys by scale/department
- + Search database by description, key word or PLU number
- + Swipe between screens for operator ease of use
- + Flashkeys can be laid out by categories or groups
- + Product shelf life by days or hours
- + Operator, product, and/or recipe notes
- + Onscreen operator manual and tutorial videos
- + COOL (country of origin labeling) can be created and modified on the scale
- + Ability to require operator login
- + Label graphics visible in supervisor mode
- + Extensive scale backup in supervisor mode
- + System can estimate number of additional records that may be added to the scale
- + Default values for the four types of products; Fixed Weight, By Count, Random Weight, and Fluid Ounces
- + UPC, EAN 13, EAN 128 Barcodes and GS1 DataBar
- + Onscreen alphanumeric keyboard and keypad
- + Cassette label loading system provides fast and efficient change of label stock
- + Meets federal labeling requirements
- + Track operator changes
- + Remotely access the scale from your help desk

### SOFTWARE

- + Linux embedded operating system 
- + Interfaces with scale management software such as:
  - Invatron's PLUM
  - ADC's Interscale
  - Genesis Software
  - Data GateWeigh
  - HCT
  - Hobart HTe
    - Content management
    - Label editing
    - Remote updates

HT SCALE SERIES - HTS

Approved by \_\_\_\_\_ Date \_\_\_\_\_ Approved by \_\_\_\_\_ Date \_\_\_\_\_

## TECHNICAL SPECIFICATIONS

- + 10.1" touch screen operator display - WSVGA TFT LCD, LED backlit, 5 wire resistive type
- + 7" standard customer display - WVGA TFT LCD, LED backlit
- + Single-core processor
- + 1GB DDR3 RAM
- + 8GB storage media
- + 802.3 10/100 Mbps Ethernet or 802.11 a/b/g/n (Ethernet standard, wireless is optional)
- + One external USB 2.0 port
- + High resolution thermal printhead for detailed graphics (store logos) and smaller bar codes - 203 dpi (8 dots per mm)
- + Accepted labels:
  - 1.5" and 2.25" width
  - 1" to 9.5" length die cut labels
  - Continuous labels
  - Oval labels

## SPECIFICATIONS

**Platter:** 14" wide x 15" deep

**Weigher Capacity:**

0 lb. - 12 l.b x 0.005 (0 - 6 kg x .002 kg)  
 12 lb. - 30 lb. x 0.01 (0 - 15 kg x .005 kg)

**Pricing Capacity:** Up to 999.99 in steps of .01

**Electrical:** 100-240 volts, 50-60 Hz, single phase, 1.42 amps max, 170 watts max. 9 foot standard cord cap with ground type plug furnished. Idle mode power consumption 18.8 W.

**Media Support:** MPEG4, AAC, AVC/H.264

**Weights and Measures Certification:**

- + USA Certification - 13-101
- + Canada Certification - AM-5927C

**Environment:** Operating temperature limits are 14°F (-10°C) to 104°F (40°C) ambient. Scale operates satisfactorily in relative humidity of 10 to 85%.

**Shipping Weight:** 34 lbs.

## DETAILS AND DIMENSIONS

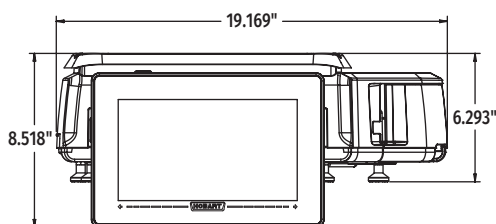
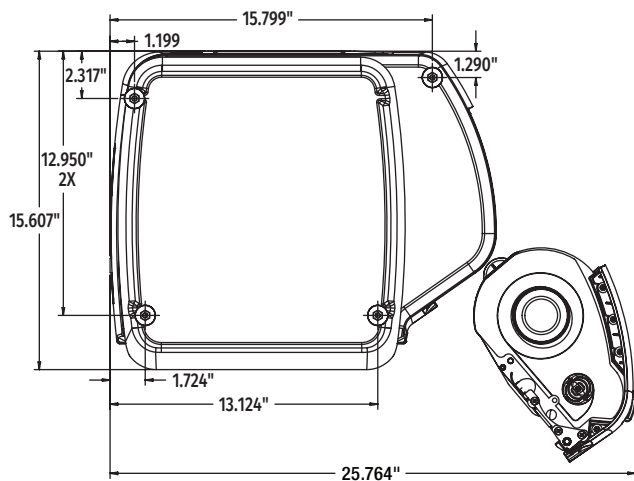

The below diagram reflects the customer facing panel for the HTs-7LS.

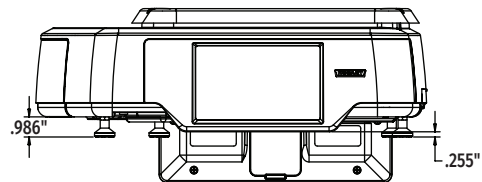

The below diagram reflects the customer facing panel for the HTs-LS and the HTsP-LS.

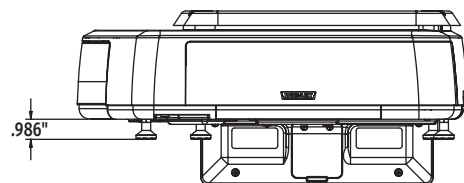

The customer facing panel for the HTs-LS and HTsP-LS is a solid black plate.

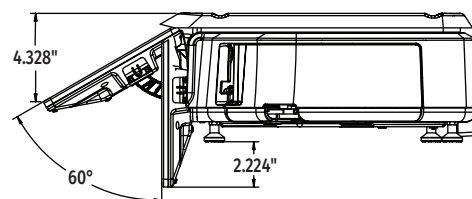

As continued product improvement is a policy of Hobart, specifications are subject to change without notice.