



Project _____
 AIA # _____ SIS # _____
 Item # _____ Quantity _____ C.S.I. Section 114000



FP350 Continuous-Feed Food Processor



SPECIFIER STATEMENT

Specified unit will be an NSF rated Hobart continuous-feed food processor with a large, easily removable feed hopper. Food processor has all aluminum hopper and housing and is compact for easy storage. Powerlink lever makes it easier for the user to process ingredients. Unit can process up to 26 pounds per minute with plate speeds at 430 RPMs and the exclusive decoring screw deflects product away from plate hub for complete processing. Cutting tools available include slicing, julienne, shredding, grating and dicing plates.

MODELS

- FP350** Continuous-Feed Half Hopper Food Processor

STANDARD FEATURES

- + Red OFF, Green ON button
- + 1 HP motor with overload protection
- + Compact design
- + Front angled at 45°
- + Planetary drive
- + Large, removable full-size feed hopper
- + All-aluminum hopper and housing
- + Double interlock switch
- + Plate speed of 430 RPMs
- + Decoring screw
- + Hobart Ergo Loop pusher plate
- + Powerlink lever
- + No Volt Release

ACCESSORIES (Available at extra cost)

- 3-Pack Plates: 1/16, 5/32 slicer plates, 3/16 shredder plate, 1 wall rack
- 6-Pack Plates: 1/16, 5/32, 3/8, 7/32, slicer plates, 5/16 shredder plate, and 3/8 dicer plate, 2 wall racks
- 3-Peg Wall Rack: designed to hold three plates for additional plate storage
- Slicer Plates: 1/32, 1/16, 1/8, 5/32, 7/32, 5/16, 3/8, 9/16
- Crimping Plate: 5/32
- Soft Slicing Plates: 5/16, 3/8, 1/2, 5/8
- Julienne Plates: 5/64, 5/32, 3/8
- Dicer Grids: 7/32, 9/32, 3/8, 1/2, 5/8, 3/4, 1
- Shredder Plates: 1/16, 5/64, 1/8, 5/32, 7/32, 5/16, 3/8
- Grater Plate: Fine, hard cheese
- Machine Table: Adjustable height to hold Food Processor
- Adjustable height stainless steel lug cart
- Stainless steel receiving pan
- Plastic receiving pan

FP350 CONTINUOUS-FEED FOOD PROCESSOR

Approved by _____ Date _____ Approved by _____ Date _____

SOLUTIONS / BENEFITS

PERFORMANCE

1 HP Motor with Overload Protection

Large, Full-Size Feed Hopper

- + Supports processing capabilities for large variety of products and eliminates pre-cutting
- + Design permits continuous cutting of long products

Plate Speed of 430 RPMs

- + Precise cutting and dicing action without bruising or mashing product

Compact Design

- + Plates remove in seconds
- + Occupies minimal counterspace

Decorating Screw

- + Deflects products away from the plate hub for complete processing

EASE OF USE

Front Angled at 45°

- + 45 degree angle for ease of product loading
- + Helps to reduce operator fatigue

All-Aluminum Hopper and Housing

- + Anodized finish resists harsh cleaners
- + Easy clean up

Compact Design

- + Occupies minimal counterspace
- + Production capacity for 26 pounds per minute

Powerlink

- + Less downward pressure needed to process dense products

Ergo Loop

- + Operator can use either hand to push feeder and load product

SANITATION & CLEANING

All-Aluminum Hopper and Housing

- + Anodized finish resists harsh cleaners
- + Easy clean up

Large, Removable Full-Size Feed Hopper

- + Flexibility, convenience, reduced labor
- + Supports processing capabilities for large variety of products and eliminates pre-cutting
- + Design permits continuous cutting of long products

OPERATOR ASSURANCE

Double Interlock Switch

- + Prevents machine from running when pusher plate swings away or is open

No Volt Release

- + Unit will not automatically turn on if power is lost

SPECIFICATIONS

Electrical: 120/60/1, 3 conductor power cord (18 AWG) is 6 feet in length.

Motor: 10 amps. Planetary gear driven operating at 430 RPM output. 1 HP with overload protection.

Switches: Easy to operate (red) OFF and (green) ON switch. Pusher plate and feed hopper interlocks.

Standard Equipment: Basic unit with deflector plate, decorating screw and cleaning brush.

Warranty: Unit has full one-year warranty on parts, labor and mileage against manufacturer's defects. Service contracts are available.

Cutting Tools: Slicer, julienne and shredder plates feature stainless steel plates with cutlery-grade stainless steel knives. Grate plates feature stainless steel cutting plates with thermoplastic support hubs. Dicing grids have molded ring construction to support stainless steel knives. Plate combinations for dicing operations are shown in the table on page 3.

Weight: Shipping - 77 lb.; Net - 71 lb.

DETAILS AND DIMENSIONS

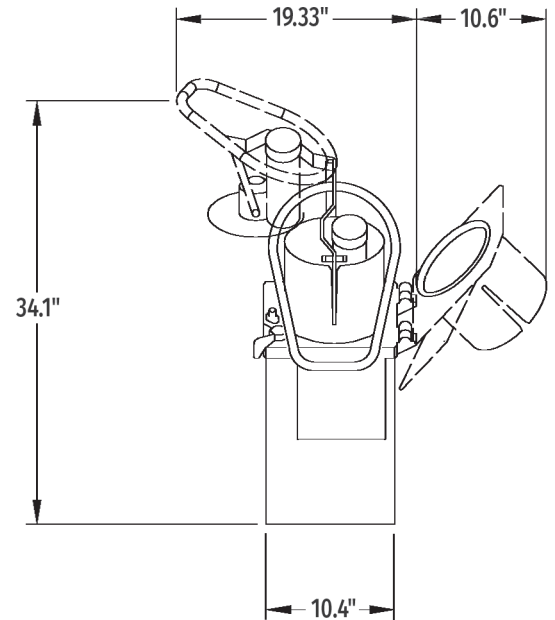
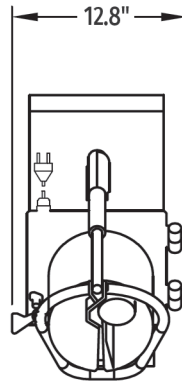
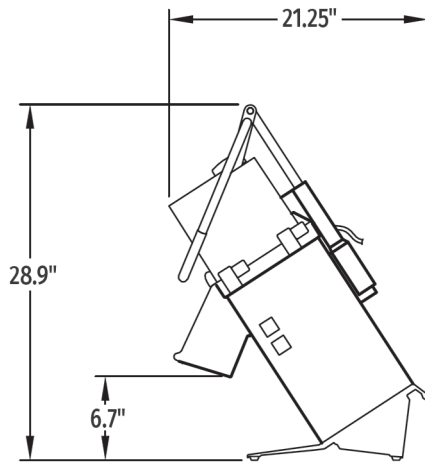

WARNING: Electrical and grounding connections must comply with the applicable portions of the National Electrical Code and/or other local electrical codes.

LEGEND

Electrical Connection	
E1	Approximately 12" above counter top

Plugs and Receptacles:

Machine Voltages	
Service Current Requirement if Plug Connected	110-120/60/1 15, 20 Amp.
Terminal Designation of Plug	2 Pole 3 Wire Grounding
NEMA Plug Configuration	5-15P
Plug Configuration	
Molded Plug on Cord	Yes
Plug - Straight/Angle	Straight
NEMA Receptacle or Connector Configuration	5-15R

FP350 Food Processor												
	S35DICE-7/32	S35DICE-9/32	S35DICE-3/8	S35DICE-1/2	S35DICE-1/2LOW	S35DICE-5/8	S35DICE-5/8LOW	S35DICE-3/4	S25DICE-3/4LOW	S35DICE-1	S35DICE-1LOW	S3FRY-3/8
3SLICE-1/32-SS												
3SLICE-1/16-SS												
3SLICE-1/8-SS	✓	✓	✓	✓		✓		✓		✓		
3SLICE-5/32-SS	✓	✓	✓	✓		✓		✓		✓		
3SLICE-7/32-SS	✓	✓	✓	✓		✓		✓		✓		
3SLICE-5/16-SS		✓	✓	✓		✓		✓		✓		
3SLICE-3/8-SS			✓	✓		✓		✓		✓		✓
3SLICE-9/16-AL							✓		✓		✓	
35SFSLC-5/16		✓	✓	✓		✓		✓		✓		
35SFSLC-3/8			✓	✓		✓		✓		✓		
35SFSLC-1/2					✓		✓					
35SFSLC-5/8							✓					