



OWNER'S MANUAL



Instructions for Installation, Operation, & Maintenance of C Series Compacts: Undercounter Refrigerators & Freezers* Prep Tables and Mega Tops*

*Please Note: This manual is intended for use with the above referenced equipment manufactured after February 1, 2026.

4401 Blue Mound Road Fort Worth, Texas 76106 (USA)

Phone: 800.825.8220 | Service Fax: 817.740.6757 | E-mail: service@traulsen.com | Website: traulsen.com

Hours of Operation: Monday - Friday 7:30 a.m. - 4:30 p.m. (CST)

TABLE OF CONTENTS

I. THE SERIAL TAG	Page 1	V. CARE AND MAINTENANCE	Page 6
a) Serial Tag & Location	Page 1	a) Cleaning the Exterior	Page 6
b) Reading The Serial Tag	Page 1	b) Cleaning the Interior	Page 6
II. RECEIPT INSPECTION	Page 2	c) Cleaning the Condenser Coil	Page 6
III. INSTALLATION	Page 2	d) Condensate Removal System Care	Page 6
a) Location	Page 2	e) Door Re-Hinging	Page 7
b) Packaging	Page 2	f) Adjusting the Door	Page 7
c) Installing Legs or Casters	Page 2	g) Replacing the Gaskets	Page 7
d) Installing Drain Pan	Page 3	h) Preparing for Extended Shutdown	Page 8
e) Shelf Clips for Door Models	Page 3	VI. CONTROL BASICS	Page 8
f) Cord & Plug	Page 3	a) Information Menu	Page 8
g) Power Supply	Page 3	b) Adjusting Cabinet Setpoint	Page 8
h) Clearance	Page 3	c) Initiating a Defrost	Page 8
i) Cutting Board Assembly	Page 4	d) Configuration Parameters	Page 9
j) Installing Backsplash	Page 4	e) Technical Data	Page 9
IV. OPERATION	Page 4	f) Components and Wiring Diagram	Page 14
a) Operation Display Indicators	Page 4	VII. TROUBLESHOOTING GUIDE	Page 15
b) Refrigerators	Page 5	VIII. SERVICE/WARRANTY INFORMATION	Page 16
c) Freezers	Page 5	a) Service Information	Page 16
d) Prep Table & Mega Top Refrigerator	Page 5	b) Spare Parts Information	Page 17
e) Refrigerating Product	Page 5	c) Warranty Registration	Page 17
f) Divider Bars	Page 5	IX. NOTES	Page 18









I. THE SERIAL TAG

I. a - SERIAL TAG & LOCATION

The serial tag is a permanently affixed label on which is recorded vital electrical and refrigeration data about your Traulsen product, as well as the model and serial number. This tag is located in upper right interior compartment on all compact models.

I. b - READING THE SERIAL TAG

- **Model** = The model # of your Traulsen unit
- **(S/N) Serial Number** = The permanent ID# of your Traulsen unit
- **Refrigerant SYS1** = System 1 Refrigerant type used and refrigerant charge
- **Design Pressure** = System 1 High and Low Pressure
- **Refrigerant SYS2** = System 2 Refrigerant type used and refrigerant charge
- **Design Pressure** = System 2 High and Low Pressure
- **Volts** = Voltage
- **Hz** = Cycle
- **PH** = Phase
- **Total Current** = Maximum amp draw
- **Min Circuit Amps** = Minimum circuit ampacity
- **Lights** = Light wattage
- **Agency Labels** = Designates agency listings
- **Components** = Component Ratings

		ITW Food Equipment Group, LLC North American Refrigeration 4401 Blue Mound Rd. Ft. Worth, TX 76106 800-825-8220		
		MODEL: MODELO: MODELE:	CLUC-27F-DW	
SERIAL NUMBER:	26A		SCAN FOR SERVICE INFO	
REFRIGERANT / REFRIGÉRANTE / RÉFRIGÉRANT				
SYS1 (REFM):	R-290	2.10 OZ	59.53 g	59.53 g
HI Press. (PRESH):	450.00 psi	3,102.64 kPa	3,102.64 kPa	
Lo Press. (PRESL):	200.00 psi	1,378.95 kPa	1,378.95 kPa	
SYS2 (REFA):	NA			
HI Press. (PRESH):				
Lo Press. (PRESL):				
Input Power (ELIN) - FOR INDOOR USE ONLY				
Voltage	Hertz	Phase	Total Amps	
115 ~	60	1	5.30	
Device/Part Number: CLUC-27F-DW		Device/Part Notes:		
				
				
				
				
COMPONENTS / COMPOSANTS / COMPONENTES				
	1	2	MAX OVER CURRENT PROTECTION (A):	
COMP AMPS:			MIN CIRCUIT IN AMPS:	
COND FAN AMPS:			DOME LIGHT WATTS:	
EVAP FAN AMPS:			DISPLAY LIGHT WATTS:	
CONTROL AMPS:			DOOR HEATER WATTS:	
DEF HEATER WATTS:			B/TMCE HTR WATTS:	
370-60297-00 REV. D 01/15/2024				

II. RECEIPT INSPECTION

II. a - RECEIPT INSPECTION

All Traulsen products are factory tested for performance and are free from defects when shipped. The utmost care has been taken in crating this product to protect against damage in transit.

You should carefully inspect your Traulsen unit for damage upon delivery. If damage is detected, you should save all the crating materials and make note on the carrier's Bill of Lading describing this. A freight claim should be filed immediately. If damage is subsequently noted during or immediately after installation, contact the respective carrier and file a freight claim. Under no condition may a damaged unit be returned to Traulsen without first obtaining written permission (return authorization). You may contact Traulsen customer care at (800) 333-7447 and select option 2 to request a return.

SYSTEMS USING REFRIGERANT R-290 (PROPANE)

Traulsen has selected propane as the refrigerant for many of their products.

In addition to its low global warming potential and impact on the environment, propane is an ideal refrigerant. It is a flammable refrigerant, however, which is why you will see a "flammable refrigerant" sticker on applicable products. Traulsen products using propane as the refrigerant are UL approved and are safe to use in accordance with this Owner's Manual and general industry practices for commercial cooking environments.

Please check with local codes or regulations for any restrictions to products using hydrocarbon refrigerants.

III. INSTALLATION

III. a - LOCATION

Select a proper location for your Traulsen unit, away from extreme heat or cold. Allow enough clearance between the unit and the side wall in order to make use of the door stay open feature at 120° (self-closing feature operates up to 90°). The door(s) must be able to open a minimum of 90° in order to make use of the maximum clear door width available.

NOTE: Do not install the cabinet without casters.

III. b - PACKAGING

All Traulsen units are shipped on casters from the factory, secured to a sturdy wooden pallet using tie-wraps and packaged in a durable cardboard container.

The cabinet should remain secured to the pallet during

III. INSTALLATION (continued)

transportation, to the point of installation. To remove the cabinet from the wooden pallet, cut the tie-wraps using a cutter. Ensure that the cabinet is properly supported during this process.

NOTE: Traulsen does not recommend laying the unit down on its front or side or back. However, if you must only lay unit on the front of side, not the back and please be certain to allow the unit to remain in an upright position afterwards for 24 hours before plugging it in so that the compressor oils and refrigerant may settle. III. c -

III. c - INSTALLING LEGS OR CASTERS

A set of 4" high casters are supplied standard for all compact undercounter and prep table units. These are installed as standard on the cabinet from the factory. Casters with locks are installed in the front for easy access to the locking mechanism.

Legs & 6" casters are available in lieu of 4" casters as an optional accessory kit for the same models. They are shipped inside a separate cardboard box, containing four/six (4/6) casters/legs.

⚠ WARNING THE CABINET MUST BE BLOCKED AND STABLE BEFORE INSTALLING CASTERS.

To change the legs or casters, first raise and block the cabinet a minimum of 7" from the floor. Remove existing casters by turning them counter-clockwise. For installing new legs/casters, thread the legs into the threaded holes on the bottom of the cabinet (see figure 1). Be certain that all legs are tightly secured.

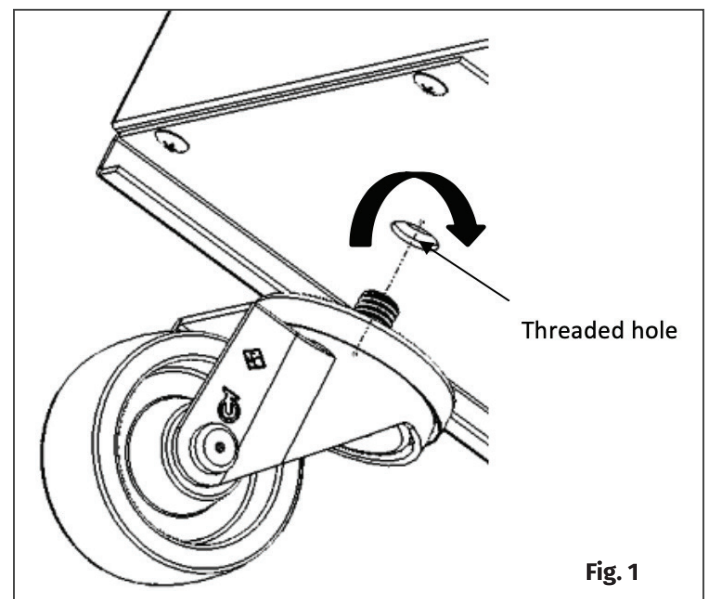

III. INSTALLATION (continued)

III. d - INSTALLING DRAIN PAN

C Series compact models are shipped with the condensate pan (half-size sheet pan) wrapped up and stored inside the unit.

Remove the condensate pan and slide it on the rails underneath the cabinet. Route the drain tubing drain into the pan to ensure water drains into the pan (see figure 2).

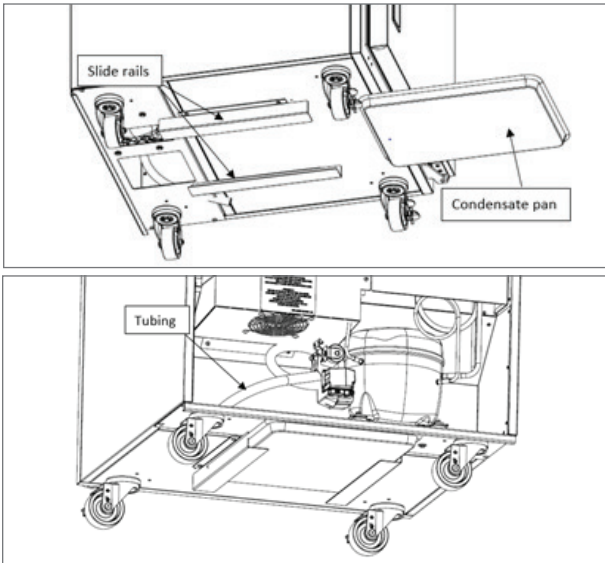

Fig. 2

NOTE: DRAIN PAN IS DESIGNED TO HOLD AND EVAPORATE DEFROST CONDENSATE FROM THE CABINET DURING NORMAL OPERATIONS. HOWEVER, DUE TO OTHER OPERATIONS LIKE FLOOR CLEANING WITH WATER JETS/SPRAYS, IT MAY GET FULL AND OVERFLOW. IN THOSE CASES, DRAIN PAN CAN BE SLIDED OUT AND EMPTIED TO PREVENT SLIP HAZARD.

III. e - SHELF CLIPS FOR DOOR MODELS

Shelves and shelf clips are shipped with the unit. Shelves are mounted on pilasters using clips to adjust the shelf height. For each shelf, insert four (4) shelf clips into the pilaster slots at the same height. The shelf clips have a small projection on top which holds the shelf in position and prevents it from slipping forward. To remove the clips, pinch down on the mounting side and pull them outwards. Make sure the clips are securely installed. Lastly, set the shelf into its new position.

III. e - SHELF CLIPS FOR DOOR MODELS (cont'd)

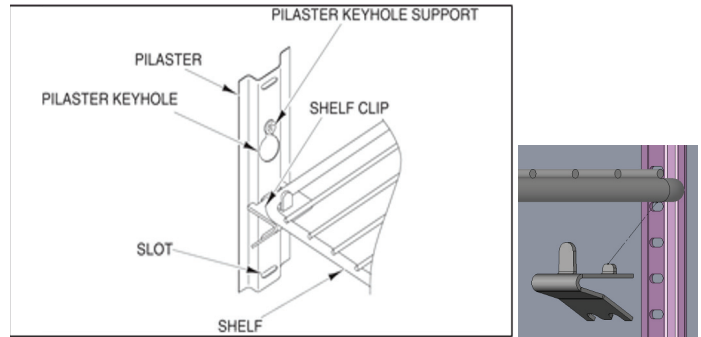

Fig. 3

III. f - CORD & PLUG

All C Series compact models are supplied with a cord & plug attached. It is shipped coiled and secured by a nylon strip to the back of the cabinet near condensing unit area. For your safety and protection, all units supplied with a cord and plug include a special three-prong grounding plug on the service cord. Select only a dedicated electrical outlet with grounding plug for power source.

NOTE: DO NOT UNDER ANY CIRCUMSTANCES CUT OR REMOVE THE ROUND GROUNDING PRONG FROM THE PLUG OR USE AN EXTENSION CORD.

III. g - POWER SUPPLY

The supply voltage should be checked prior to connection to be certain that proper voltage for the cabinet wiring is available (refer to the serial tag to determine correct unit voltage). Make connections in accordance with local electrical codes. Use qualified electricians.

Use of a separate, dedicated circuit is required. Size wiring to handle indicated load and provide necessary over current protector in circuit (see amperage requirements on the unit's serial tag).

III. h - CLEARANCE

In order to assure optimum performance, the condensing unit of your C Series unit **MUST** have an adequate supply of air for cooling purposes. Therefore, the operating location must have a minimum of 1" clearance on top of the unit for proper air flow. There are no clearance requirements for the sides or rear.

III. INSTALLATION (continued)

III. i - CUTTING BOARD ASSEMBLY

On prep tables and mega top tables, the cutting board may require assembly at the site.

Install cutting board brackets on each side with two screws. With brackets installed, slide the cutting board in at an angle under the lip in the back and then let it rest down with the pins running through the holes on the board (see figure 4). The cutting board is field reversible, reverse process to reverse cutting board.

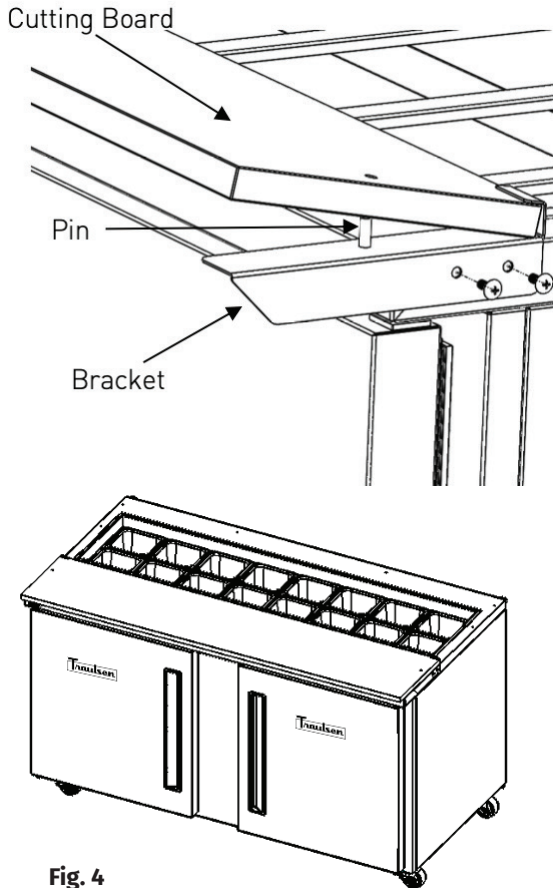

Fig. 4

III. j - INSTALLING BACKSPLASH

All 27", 36", 48", 60", & 72" wide compact undercounter models can be supplied with an optional backsplash that must be installed on-site. To do so, please follow the directions below:

III. j - INSTALLING BACKSPLASH (cont'd)

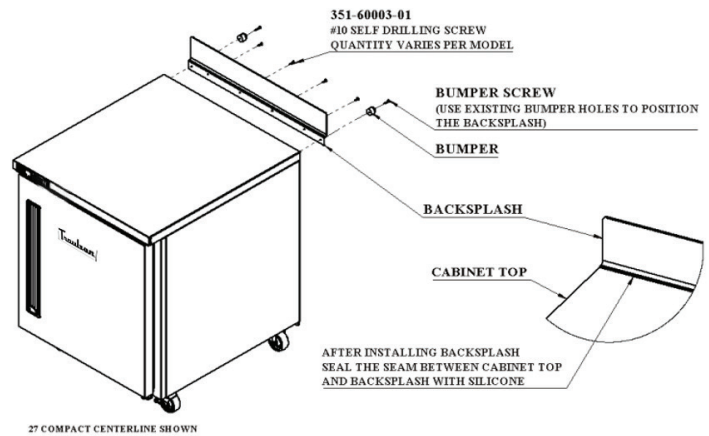

Fig. 5

1. Install backsplash as shown in figure 5. The backsplash is attached with self-drilling Philips head screws. The outer most holes are used to install bumpers.
2. Align the outer holes used for the bumpers to attach the backsplash. Attach the backsplash with the just the outer holes and bumpers temporarily to hold in place.
3. Assure the front lip of the backsplash is contacting the top of the unit. Use the self-threading sheet metal screws to attach the inner portion through the hole locations on the backsplash.
4. Use silicone or similar product to seal any gaps between the backsplash and the exterior top.

IV. OPERATION

Both refrigerators and freezers do not require manual defrosting. However, manual defrost option is available on the control, if required.

IV. a - OPERATION DISPLAY INDICATORS

During normal operation, the display shows either the temperature measured or one of the following indications:

<i>dEF</i>	Defrost in progress
<i>oFF</i>	Controller in stand-by
<i>cL</i>	Condenser clean warning
<i>do</i>	Door open alarm
<i>E1</i>	Probe T1 failure
<i>E2</i>	Probe T2 failure
<i>E3</i>	Probe T3 failure

IV. OPERATION (continued)

IV. b - REFRIGERATORS

During normal operation, a refrigerator continuously circulates above-freezing cabinet air through the evaporator coil. An Off-Cycle defrost occurs every 8 hours for a maximum length of 50 minutes to melt any frost which may accumulate on the coil during the compressor “ON” cycle. With standard holding refrigerators, high relative humidity is also maintained to prevent dehydration of stored product.

IV. c - FREEZERS

During normal operation, a freezer continuously circulates below-freezing cabinet air through the evaporator coil. The coil requires a periodic defrosting for proper operation. This is accomplished by an automatic, compressor runtime activated, temperature/time terminated, defrost program. Depending on the door opening frequency and the ambient condition, the defrost may occur 3 to 8 times within each 24-hour period.

At the start of a freezer defrost cycle, both the compressor and evaporator fans are off. The microprocessor control will read “dEF” (see figure 6).



Fig. 6

The electric heaters (attached to the evaporator coil and drip pan) are energized. When the temperature sensor affixed to the coil senses 50°F, the coil and drip pan are fully defrosted. Both heaters and compressor are off for 5 minutes to let the defrost water drip out completely. After drip time, compressor will resume operation. The evaporator coil fans are delayed from starting at the termination of a defrost cycle. Fan operation is automatically resumed after a short time or temp delay (whichever comes first). After completion, the total refrigeration system operation is then resumed. During defrost operation, heat is confined to the coil enclosure to prevent any significant rise in temperature within the food zone. The fan delay control function upon termination of a defrost cycle is two-fold. First, to prevent blowing warm air into the food storage area. Second, to prevent any condensation on the defrost coil from being blown into the food storage area.

IV. c - FREEZERS (cont'd)

The microprocessor control is set from the factory to terminate defrost at 25 minutes for freezers in the event of a sensor failure. This setting should never be tampered with, without first consulting the factory.

IV. d - PREP TABLE & MEGA TOP REFRIGERATOR

The prep table and mega top refrigerator will function as a refrigerator. Due to the open top feature, it runs slightly lower evaporator temperature and builds more frost on coil than the regular refrigerator. The prep table and mega top therefore utilize electric heater for more effective defrost. The defrost procedure is the same as in freezer described in section IV.c, except the defrost will be terminated at 45°F

IV. e - REFRIGERATING PRODUCT

C Series compact models will satisfactorily refrigerate an assorted load of food items. Allow space between articles to permit free air circulation. Do not overload at any one time with warm food products and expect immediate results. A certain amount of time is required to remove heat from items before operating temperatures can be attained. The system is designed for storage of refrigerated or frozen product.

Opening the door or drawer will increase the temperature in the cabinet and will require a certain amount of time to recover. Also, after peak service periods or after warm product is loaded, the refrigerator will require a certain amount of time for the temperature to return to the normal operating range.

IV. f - DIVIDER BARS

Top Rail: C Series compacts are provided with standard width pan divider bars. Pans are not provided with the unit.

Drawers: Drawer models are provided with metal divider bars standard. All 27” wide models are supplied with standard width bars. 48” and 72” models are supplied with 2 narrow and 2 wide bars.

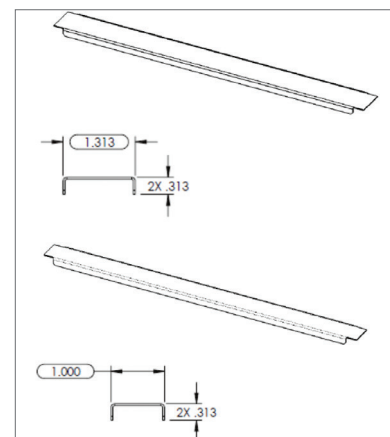

Fig. 7

V. CARE AND MAINTENANCE

⚠ WARNING **DISCONNECT ELECTRICAL POWER SUPPLY BEFORE CLEANING ANY PARTS OF THE UNIT.**

V. a - CLEANING THE EXTERIOR

Exterior stainless steel should be cleaned with warm water, mild soap and a soft cloth. Apply with a dampened cloth and wipe in the direction of the metal grain.

Avoid the use of strong detergents and gritty, abrasive cleaners as they may tend to mar and scratch the surface. Do NOT use cleaners containing chlorine, this may promote corrosion of the stainless steel.

V. b - CLEANING THE INTERIOR

For cleaning the interior, use baking soda with warm water, and a soft cloth. Apply with a dampened cloth and wipe in the direction of the metal grain Use on breaker strips as well as door and drawer gaskets.

All door models interior fittings are removable without tools to facilitate cleaning. Depending on the level of cleaning, drawer model interior fittings may require a tool to facilitate cleaning. The drawer frame may be removed without tools.

To remove the drawers, the lock tab must be unlocked by sliding the lock tab forward and then up, to loosen the slides (see figure 8). Then the drawer can be pulled out easily. from the slides.

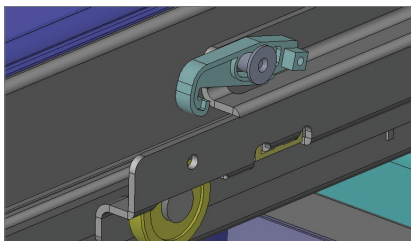

Drawer lock tab shown in unlocked position.

Fig. 8

To remove the middle slide between the drawer and cabinet for deeper cleaning, remove the middle slide by lifting up on the back tab and sliding it out of the track.

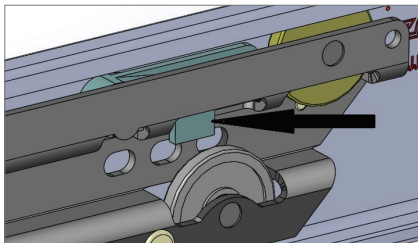
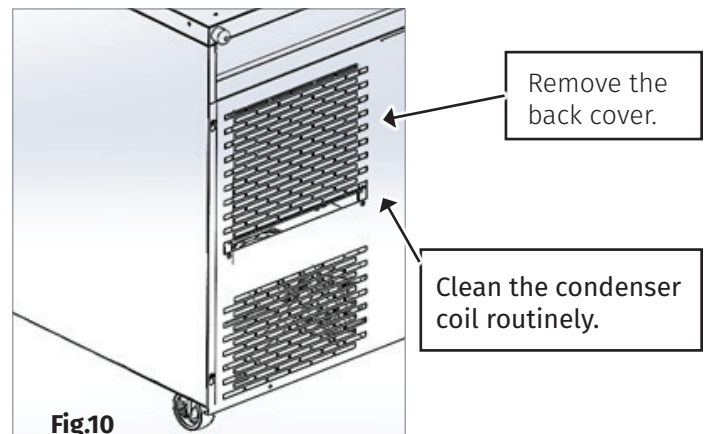

Fig. 9

Caution: The outer slides attached the side of the cabinet should not be removed because there are washers set in the assemble to hold the proper spacing between the slides. If removed the drawer slides may not function properly.

V. c - CLEANING THE CONDENSER COIL

Clean the condenser coil every three months. The operating environment will affect the required frequency of cleaning. Air must be able to freely circulate through the condenser. This surface must be kept free of dirt and grease for proper system operation. The condenser coil is at the back of the cabinet and comes with a back cover installed. This cover should stay on while the unit is working. For cleaning purposes, take off the back cover and carefully clean dirt and lint from the condenser coil using a vacuum cleaner or soft brush; do not use a wire brush. To remove the cover, remove the thumb screw and then slide it through the keyholes. After cleaning, re-install the back following the same steps listed above. Ensure that the thumb screw is installed to lock the cover in place.



SYSTEMS USING REFRIGERANT R-290 (PROPANE)

Remove any ignition source (arc, flame, heat) before cleaning the condenser coil. If the condenser coil is inadvertently damaged during cleaning to the point of causing a refrigerant leak, immediately ventilate the area and call for service.

V. d - CONDENSATE REMOVAL SYSTEM CARE

Condensate removal is provided by evaporation at the pan at the bottom of the equipment cabinet and does not need a drain. Clean the condensate removal pan by wiping it out with a clean damp cloth. Replace the pan back to its location

V. CARE AND MAINTENANCE (continued)

V. e - DOOR RE-HINGING

The door(s) on all compact models can be easily re-hinged in the field. Existing hinge cartridge and top hinge bracket can be reused but an opposite side bottom hinge bracket will be needed. This bracket can be obtained from the factory by contacting our parts department (see section VIII.b) To begin, open the door to its stay-open feature position. Support the non-hinged end of the door so that minimum movement occurs when the bolts from the lower hinge brackets are removed. Remove the lower hinge bracket and then the door from the top hinge bracket. The hinge bracket pin and plastic bushing will remain in the top hinge bracket.

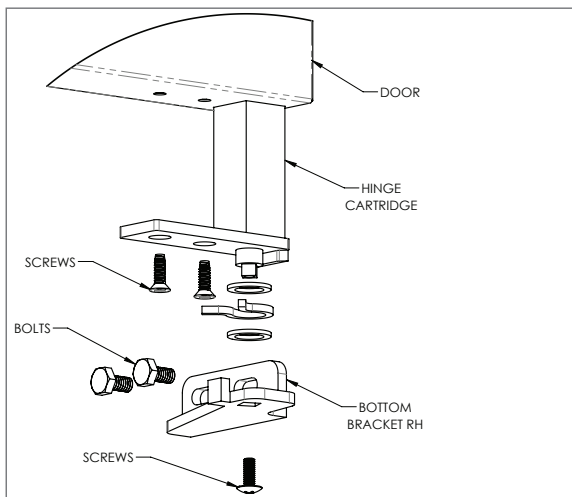

Fig. 11

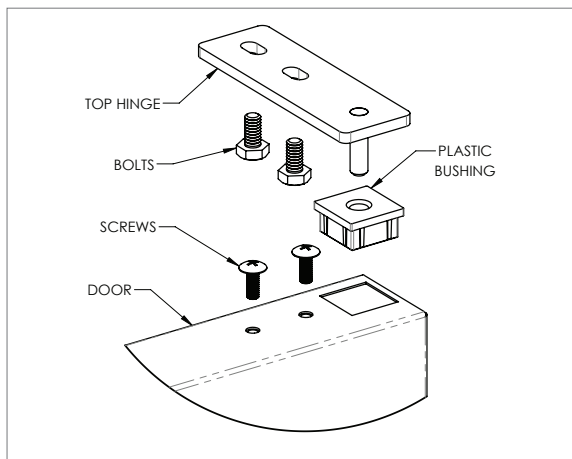

Fig. 12

Carefully lay the door down on a padded flat surface. The door must be rotated 180° to mount on the other side of cabinet. Remove top bushing and bottom hinge cartridge and install on opposite ends. Using the newly obtained bottom hinge bracket, follow the steps in reverse order to re-hinge the door.

V. e - DOOR RE-HINGING (cont'd)

NOTE: The lower hinge plate is under spring tension. Grasp the lower hinge plate while keeping a firm grip on the plate, carefully slide it out the bottom of the door just far enough to allow the plate to rotate a full 360°. Unwind the tension of the spring by carefully allowing the hinge plate to rotate a full 360 degrees several times.

V. f - ADJUSTING THE DOOR

Occasionally the door(s) may require alignment adjustment. To do so, first open the door and loosen the hinge plate screws enough to move the hinges if desired, but the door is held in place. Center the door in the opening. Next level the top hinge plate and tighten the screws. Finally, level the lower hinge plate and tighten the screws.

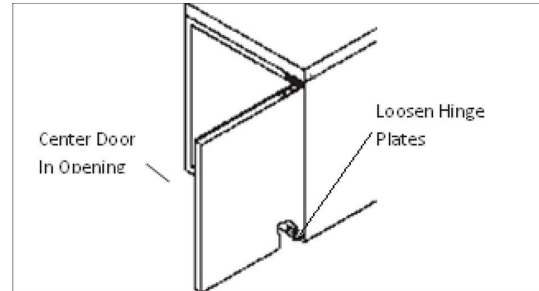

Fig. 13

V. g - REPLACING THE GASKETS

To replace the gasket, grasp it firmly by one corner and pull it out. Before attempting to install a new gasket, both the unit and gasket must be at room temperature. Insert the four corners first by using a rubber mallet (or hammer with a block of wood). After the corners are properly inserted, work your way towards the center from both ends by gently hitting with a mallet until the gasket is completely seated in place (see figure 14 for proper gasket placement).

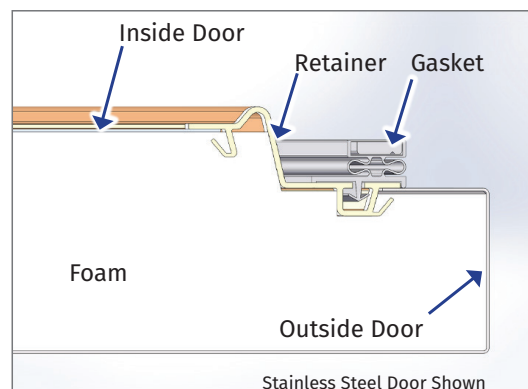

Fig. 14

V. CARE AND MAINTENANCE (continued)

V. h - PREPARING FOR EXTENDED SHUTDOWN

If the refrigerator is not to be used for an extended period of time, disconnect the electrical power supply and open the doors. As soon as the cabinet has warmed up to room temperature, wipe out the interior. Leave the doors open and check again to make sure that no moisture has collected on any parts. To restart refrigerator, follow instructions under PRESTART CHECKS and OPERATION.

VI. CONTROL BASICS

Your new Traulsen Refrigerator or Freezer is equipped with a digital control, which precisely regulates operation. It is supplied from the factory completely ready for use.

VI. a - INFORMATION MENU

The information available in this menu is:

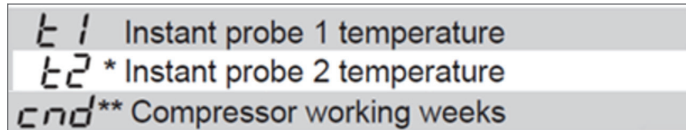

* displayed only if enabled (see Configuration Parameters)

** displayed only if ACC > 0

Access to menu and information displayed:

- Press and immediately release button **i**.
- With button **▼** or **▲** select the data to be displayed.
- Press button **i** to display value.
- To exit from the menu, press button **✕** or wait for 10 seconds.

Initiate Stand-By:

Keeping the button **⏻** pressed for 3 seconds allows the controller to be put on a standby or output control to be resumed (with **SB**=YES only).

Locking the Keypad:

The keypad lock avoids undesired, potentially dangerous operations, which might be attempted when the controller is operating in a public place. In the INFO menu, set parameter **LOC** = YES to inhibit all functions of the buttons. To resume normal operation of keypad, adjust setting so that **LOC** = NO.

VI. b - ADJUSTING CABINET SETPOINT

Setpoint display and modification:

- Press button **i** for at least a half second to display the setpoint value.
- While keeping the **i** button pressed, use button **▼** or **▲** to set the desired value (adjustment is within the minimum **SPL** and the maximum **SPH** limit).

VI. CONTROL BASICS (continued)

- When button **i** is released, the new value is stored.

VI. c - INITIATING A DEFROST

Automatic defrost:

Defrost starts automatically as soon as the time set with parameter **DFT** has elapsed.

- Timed defrost: With **DFM** = TIM defrosts take place at regular intervals when the timer reaches the value of **DFT**. For example, with **DFM** = TIM and **DFT** = 36, a defrost will take place every 6 hours.
- Optimized defrost: With **DFM** = FRO the timer is only increased when the conditions occur for frost to form on the evaporator, until the time set with parameter



DFT is matched. If the evaporator works at 0°F, defrost frequency depends on the thermal load and climatic conditions. With setpoints much lower than 0°F, defrost frequency mainly depends on the refrigerator operating time.

- Defrost time count backup: At the power-up, if **DFB** = YES, the defrost timer resumes the time count from where it was left off before the power interruption. Vice versa, with **DFB** = NO, the time count re-starts from 0. In stand-by, the accumulated time count is frozen.

Manual or remote defrost start:

It's possible to manually start a defrost, by pressing button **⊞** for 2 seconds.

Defrost type. Once defrost has started, Compressor and Defrost outputs are controlled according to parameter **DTY**. If **FID** = YES, the evaporator fans are active during defrost.

Defrost termination. The actual defrost duration is influenced by a series of parameters.

- Time termination: **T2** = NO and **T3** different from 2EU: the evaporator temperature is not monitored and defrost will last as long as time **DTO**.
- Temperature monitoring of one evaporator: **T2** = YES and **T3** different from 2EU. In this case, if the sensor **T2** measures the temperature **DLI** before the time **DTO** elapses, defrost will be terminated in advance.

VI. CONTROL BASICS (continued)

VI. c - INITIATING A DEFROST (cont'd)











Resuming thermostatic cycle:

When defrost is over, if **DRN** is greater than 0, all outputs will remain off for **DRN** minutes, in order for the ice to melt completely and the resulting water to drain. Moreover, if probe **T2** is active (**T2** = YES), the fans will re-start when the evaporator gets to a temperature lower than **FDD**; Vice versa, if probe **T2** is not active (**T2** = NO) or after defrost has come to an end, such condition does not occur by end of the time **FTO**, after **FTO** minutes have elapsed the fans will be switched on anyway.

Caution: if **DFM** = NON or **C-H** = HEA all defrost functions are inhibited; if **DFT** = 0, automatic defrost functions are excluded.

VI. d - CONFIGURATION PARAMETERS

Parameter Configuration:

- To get access to the parameter configuration menu, press button  and  for 5 seconds.
- With button  or  select the parameter to be modified.
- Press button  to display the value.
- By keeping button  pressed, use button  or  to set the desired value.
- When button  is released, the newly programmed value is stored and the following parameter is displayed.
- To exit from the setup, press button  or wait for 30 seconds.

VI. e - TECHNICAL DATA

Power supply: 100-240Vac ±10%, 50/60Hz, 3W

Relay output max loads (240Vac)

INPUTS:				
Input Type	Terminal	Rating		
Power Supply	L-N	100-240 Vac, 50/60 Hz, Max. 5 W		
Digital Inputs	DI1, DI2	SELV 5 V, less than 15 W		
Probe	T1, T2	SELV 5 V, less than 15 W		
COMMUNICATION:				
Type/Function	Terminal	Rating		
Display	Remote (J5)	SELV 5 V, less than 15 W		
RS485	DATA (J6)	SELV 5 V, less than 15 W		
OUTPUTS(+):				
Output Terminals	Load Controlled	Switching Device and Schematic Ref	Electrical Ratings	Declaration
3 - 4	Compressor	RL1	Motor load 12 FLA 72 LRA, 240 Vac, 100k cycles	Type 1.B
			Resistive load 16 A, 240 Vac, 100k cycles	
7 - 8	Defrost Heater	RL2	Motor load 4 FLA 4 LRA, 240 Vac, 30k cycles	Type 1.B
			Resistive load 12 A, 240 Vac, 100k cycles	
9 - 12	Evaporator Fan	SSR1	Motor load (Declared specific load) 2.6 A, 240 Vac	--
10 - 11	Lights	SSR2	Inductive load 1.3 A, 240 Vac	--

Max. ampacity on the common terminal: 20 A

VI. CONTROL BASICS (continued)

PAR	RANGE	DESCRIPTION
SPL	-58..SPH	Minimum limit for SP setting.
SPH	SPL...180°	Maximum limit for SP setting.
SP	SPL... SPH	Setpoint (value to be maintained in the room).
C-H	REF; HEA	Refrigerating (REF) or Heating (HEA) control mode.
HY0	1...10°	Thermostat OFF -> ON differential.
HY1	0...10°	Thermostat ON -> OFF differential.
CRT	0...30min	Compressor rest time. The output is switched on again after CRT minutes have elapsed since the previous switchover. We recommend to set CRT=03 with HY0<2.0°.
CT1	0...30min	Compressor/Heater output run when probe T1 is faulty. With CT1=0 the output will always remain OFF.
CT2	0...30min	Compressor/Heater output stop when probe T1 is faulty. With CT2=0 and CT1>0 the output will always be ON. Example: CT1=4, CT2= 6: In case of probe T1 failure, the compressor will cycle 4 minutes ON and 6 minutes OFF.
DFM	NON; TIM; FRO CRN	Defrost start mode NON : defrost function is disabled (the following parameter will be FCM). TIM : regular time defrost. FRO : the defrost time count is only increased when the conditions occur for frost to form on the evaporator (optimized time increase). CRN : defrost is based off of compressor run time (time is based off of DAT).
DFT	0...250	Time interval among defrosts in x10 minutes. When this time has elapsed since the last defrost, a new defrost cycle is started. Each number is multiplied by 10 minutes. 0-250 indicates 0-2500 minutes.
DAT	0...100 hours	Frost accumulation timeout.
DFB	NO/YES	Defrost timer backup. With DFB=YES, after a power interruption, the timer resumes the count from where it was left off with ±30 min. approximation. With DFB=NO, after a power interruption, the defrost timer will re-start to count from zero.
DLI	-58...180°	Defrost end temperature.
DMD	0...30min	Minimum defrost duration.
DTO	1...120min	Maximum defrost duration.
DTY	OFF; ELE; GAS	Defrost type OFF: off cycle defrost (Compressor and Heater OFF). ELE: electric defrost (Compressor OFF and Heater ON). GAS: hot gas defrost (Compressor and Heater ON).
DSO	OFF; LO; HI	Defrost start optimization OFF : no optimization. LO : defrost waits until the compressor cut-out. HI : defrost waits until the compressor cut-in.
SOD	0...30 min	Start optimization delay.
DPD	0...240sec	Evaporator pump down. At the beginning of defrost, defrost outputs (determined by DTY) are OFF for DPD seconds.
DRN	0...30min	Pause after defrost (evaporator drain down time).

VI. CONTROL BASICS (continued)

PAR	RANGE	DESCRIPTION
DDM	RT; LT; SP; DEF	Defrost display mode. During defrost the display will show: RT : the real temperature; LT : the last temperature before defrost; SP : the current setpoint value; DEF : “dEF”.
DDY	0...60min	Display delay. The display shows the information selected with parameter DDM during defrost and for DDY minutes after defrost termination.
FID	NO/YES	Fans active during defrost.
FDD	-58...180°	Evaporator fan re-start temperature after defrost.
FTO	0...120min	Maximum evaporator fan stop after defrost.
FCM	NON; TMP; TIM	Fan mode during thermostatic control. NON : The fans remain ON all the time; TMP : Temperature-based control. The fans are ON when the compressor is ON. When the compressor is turned OFF, the fans remain ON as long as the temperature difference $T_e - T_a$ is greater than FDT. The fans are turned ON again with FDH differential. (T_e = Evaporator temperature, T_a = Air temperature); TIM : Timed-based control. The fans are ON when the compressor is ON. When the compressor is OFF, the fans switch ON and OFF according to parameters FT1, FT2, FT3
FDT	-12...0°	Evaporator-Air temperature difference for the fans to turn OFF after the compressor has stopped.
FDH	1...12°	Temperature differential for fan re-start.
		Example: FDT = -1, FDH=3. In this case, after the compressor has stopped, the fans are OFF when $T_e > T_a - 1$ (FDT), whereas the fans are ON when $T_e < T_a - 4$ (FDT-FDH).
FT1	0...180sec	Fan stop delay after compressor/heater stop. See Fig. 2
FT2	0...180	Timed fan stop in x10 seconds. With FT2=0 the fans remain on all the time.
FT3	0...180	Timed fan run in x10 seconds. With FT3=0, and FT2 > 0, the fans remain off all the time.
ATM	NON; ABS; REL	Alarm threshold management. NON : all temperature alarms are inhibited (the following parameter will be ACC). ABS : the values programmed in ALA and AHA represent the real alarm thresholds. REL : the alarm threshold is obtained by the sum of setpoint, thermostat differential and ALR/AHR.
ALA	-58... 180°	Low temperature alarm threshold.
AHA	-58... 180°	High temperature alarm threshold.
ALR	-12... 0°	Low temperature alarm differential. With ALR=0 the low temperature alarm is excluded.
AHR	0... 12°	High temperature alarm differential. With AHR=0 the high temperature alarm is excluded.
ATI	T1; T2; T3	Probe used for temperature alarm detection.
ATD	0... 120 min	Delay before alarm temperature warning.
ACC	0...52 weeks	Condenser periodic cleaning. When the compressor operation time, expressed in weeks, matches the ACC value programmed, “CL” flashes in the display. With ACC=0 the condenser cleaning warning is disabled and CND disappears from Info Menu.
IISM	NON; MAN; ECO; DI	Switchover mode to second parameter set NON : inhibition to use the second parameter group (the following parameter will be SB). MAN : button switches the two parameter groups over. ECO : automatic switchover to the second parameter group, when ECO conditions are detected. DI : switchover to the second parameter group when Dix input is on.
IISL	-58... IISH	Minimum limit for IISP setting.

VI. CONTROL BASICS (continued)

PAR	RANGE	DESCRIPTION
IISH	IISL... 180°	Maximum limit for IISP setting.
IISP	IISL... IISH	Setpoint in mode 2.
IIHO	1... 10°	Thermostat OFF->ON differential in mode 2.
IIH1	0... 10°	Thermostat ON->OFF differential in mode 2.
IIDF	0...250	Time interval among defrosts in mode 2 in x10 minutes.
IIFC	NON; TMP; TIM	Fan control in mode 2. See FCM.
ECS	1...5	Controller sensitivity for the automatic switchover from Group I to Group II (1=minimum, 5=maximum).
ECS	1...5	Controller sensitivity for the automatic switchover.
EPT	0...240 min	Eco pull-down time. Only with IISM=ECO. Group I parameters are used in regulation for at least EPT minutes. See Fig.3
SB	NO/YES	Stand-by button enabling.
DSM	NON; ALR; STP	Door switch input mode: NON : door switch inhibited ALR : when Dlx=DOR and the digital input is on, an alarm is generated after ADO minutes STP : when Dlx=DOR and the digital input is on, in addition to the alarm, the fans are immediately stopped and the compressor is stopped after CSD minutes.
DAD	0...30 min	Delay before door open alarm warning.
CSD	0...30 min	Compressor/heater stop delay after door has been opened.
D10	NON; DOR; ALR; IISM; RDS	D11 digital input operation NON : digital input 1 not active. DOR : door input. ALR : when the input is on, an alarm is generated (if AHM=STP, the compressor is stopped and the defrosts are suspended). IISM : when the input is on, the controller will use group 2 parameters. RDS : when the input is on, a defrost is started (remote control).
D1A	OPN; CLS.	D11 digital input activation. OPN : on open CLS : on close
D20	See D10	D12 digital input operation. See D10.
D2A	OPN; CLS.	D12 digital input activation. OPN : on open CLS : on close
PSL	-58...158	Minimum setpoint adjusted via potentiometer.
PSR	0...15	Range of setpoint adjusted via potentiometer.
LSM	NON; MAN; ECO; DI1; DI2; DI3.	Light control mode NON : light output not controlled. MAN : light output controlled through button (if OAx=LGT). ECO : lights activated/deactivated following the ECO state. Dlx : lights activated/deactivated following the Dlx state.
LSA	OPN; CLS	Light activation (only with LSM=ECO or LSM=Dlx). OPN : lights on with Dlx open or ECO mode deactivated. CLS : lights on with Dlx closed or ECO mode activated.

VI. CONTROL BASICS (continued)





PAR	RANGE	DESCRIPTION
OT1	0...600 sec	Activation time of OA1
OT2	0...600 sec	Pause between OA1 activation
OA1	NON; LGT; 0-1; 2CU; 2EU; ALO; ALC	AUX 1 output operation NON : output disabled (always off). LGT : output enabled for light control. 0-1 : the relay contacts follow the on/standby state of controller. 2CU : output programmed for the control of an auxiliary compressor. 2EU : output enabled for the control of the electrical defrost of a second evaporator. ALO : contacts open when an alarm condition occurs. ALC : contacts make when an alarm condition occurs.
2CD	0...120 sec	Auxiliary compressor start delay. If OAx=2CU the auxiliary output is switched on with a delay of 2CD seconds after the main compressor has cut-in. Both compressors are turned off at the same time.
OS1	-12.5..12.5°	Probe T1 offset.
T2	NO/YES	Probe T2 enabling (evaporator).
OS2	-12.5..12.5°	Probe T2 offset.
T3	NON; DSP; CND; 2EU	Auxiliary probe T3 operation NON : probe T3 not fitted. DSP : temperature T3 to be displayed. CND : condenser temperature measurement. 2EU : second evaporator temperature measurement.
OS3	-12.5..12.5°	Probe 3 offset.
AHM	NON; ALR; STP;	Operation in case of high condenser alarm NON : high condenser alarm inhibited. ALR : in case of alarm, "HC" flashes in the display and the buzzer is switched on. STP : in addition to the alarm symbols displayed, the compressor is stopped and defrosts are suspended.
AHT	-50...110°	Condensation temperature alarm (referred to T3 probe).
TLD	1...30 min	Delay for minimum temperature (TLO) and maximum temperature (THI) logging.
TDS	T1; 1-2; T3	Selects the temperature probe to be displayed. T1 : probe T1 1-2 : the AVG-weighted average between T1 and T2 T3 : probe T3
AVG	0...100%	The relative weight of T2 on T1 (if TDS = 1-2) Example 1: T1 = -5°, T2 = -20°, AVG = 100%. The displayed temperature will be -20° (T1 has no effect) Example 2: T1 = -5°, T2 = -20°, AVG = 60%. The displayed temperature will be -14.
SCL	1°C; 2°C; °F	Readout scale. 1°C : measuring range -50...110°C (0.1°C resolution within -9.9 ÷ 19.9°C interval, 1°C outside) 2°C : measuring range -50 ... 110°C °F : measuring range -55 ... 180°F
SIM	0...100	Display slowdown.
ADR	1...255	TRL-002 address for PC communication.
NPR	0...1	Setup programmed.
STT	0...255	Setup traceability.

VI. CONTROL BASICS (continued)

VI. f - COMPONENTS AND WIRING DIAGRAM



Indications:

-  Thermostat output
-  Fan output
-  Defrost output
-  Activation of 2nd parameter set
-  Alarm

 Manual activation / Increase button

 Exit / Stand-by button

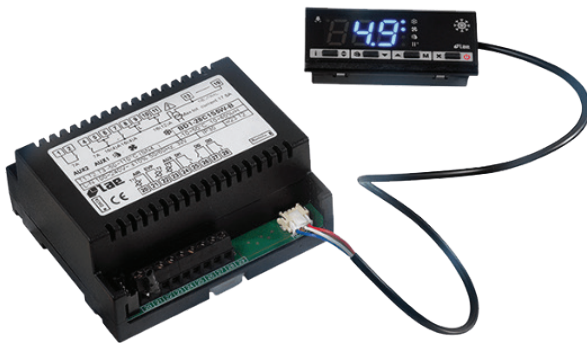

Control Wiring Diagram:

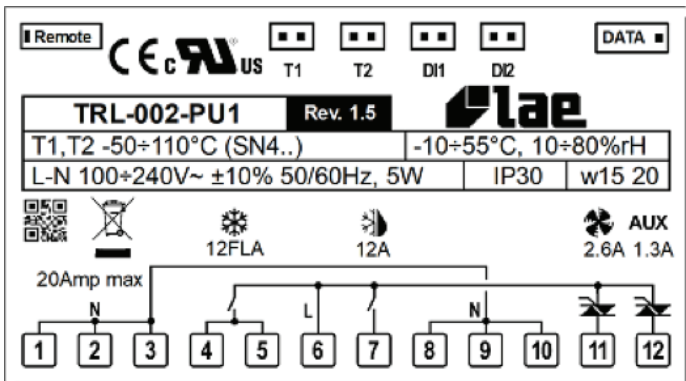

VII. TROUBLESHOOTING GUIDE

VII. a -TROUBLESHOOTING GUIDE

FIND YOUR PROBLEM HERE	REMEDY
1. Condensing unit fails to start.	<ul style="list-style-type: none"> a. Check if cord & plug has been disconnected. b. Check control temperature setting.
2. Condensing unit operates for prolonged periods or continuously.	<ul style="list-style-type: none"> a. Are doors closing properly? b. Dirty condenser or filter. Clean properly. c. Evaporator coil iced. Needs to defrost. See instructions for setting a manual defrost cycle on section VI.c.
3. Food compartment is too warm.	<ul style="list-style-type: none"> a. Check door(s) and gasket(s) for proper seal b. Perhaps a large quantity of warm food has recently been added or the door was kept open for a long period of time, in both cases, allow adequate time for the cabinet to recover its normal operating temperature. c. Control setting too high, readjust per instructions on section VI.b. d. Check that condensing coil is clean.
4. Food compartment is too cold.	<ul style="list-style-type: none"> a. Perhaps a large quantity of very cold or frozen food has recently been added. Allow adequate time for the cabinet to recover its normal operating temperature. b. Adjust the control to a warmer setting, see section VI.b.
5. Condensation on the exterior surface.	<ul style="list-style-type: none"> a. Check door alignment and gaskets for proper seal. b. Condensation on the exterior surface of the unit is perfectly normal during periods of high humidity.
6. Compressor hums but does not start.	<ul style="list-style-type: none"> a. Call for service.
7. No power to unit	<ul style="list-style-type: none"> a. Check if cord & plug has been disconnected. b. Check power supply breaker.

VIII. SERVICE/WARRANTY INFORMATION

VIII. a - SERVICE INFORMATION

Before calling for service, please check the following:

- Is the electrical cord plugged in?
- Is the fuse OK or circuit breaker on?
- Is the condenser coil clean?
- Is the power switch on?

If after checking the above items and the unit is still not operating properly, please contact an authorized Traulsen service agent:

4401 Blue Mound Road Fort Worth, TX 76106
(800) 825-8220.

Traulsen reserves the right to change specifications or discontinue models without notice.



This appliance is marked with the ISO 7010-W021 warning label to indicate the presence of **FLAMMABLE REFRIGERANTS**. Prior to beginning work on systems containing **FLAMMABLE REFRIGERANTS**, safety checks are necessary to ensure that the risk of ignition is minimized.

VENTILATED AREA

Ensure that the area is in the open or that it is adequately ventilated before breaking into the system or conducting any hot work. A degree of ventilation shall continue during the period that the work is carried out. The ventilation should safely disperse any released refrigerant and preferably expel it externally into the atmosphere.

CABLING

Check that cabling will not be subject to wear, corrosion, excessive pressure, vibration, sharp edges, or any other adverse environmental effects. The check shall also take into account the effects of aging or continual vibration from sources such as compressors or fans.

DETECTION OF FLAMMABLE REFRIGERANTS

Under no circumstances shall potential sources of ignition be used in the searching for or detection of refrigerant leaks. A halide torch (or any other detector using a naked flame) shall not be used.

The following leak detection methods are deemed acceptable for all refrigerant systems. Electronic leak detectors may be used to detect refrigerant leaks but, in the case of **FLAMMABLE REFRIGERANTS**, the sensitivity might not be adequate, or might need recalibration. (Detection equipment shall be calibrated in a refrigerant-free area.) Ensure that the detector is not a potential source of ignition and is suitable for the refrigerant used. Leak detection equipment shall be set at a percentage of the LFL of the refrigerant and shall be calibrated to the refrigerant employed, and the appropriate percentage of gas (25 % maximum) is confirmed.

Leak detection fluids are also suitable for use with most refrigerants but the use of detergents containing chlorine shall be avoided as the chlorine can react with the refrigerant and corrode the copper pipe-work.

VIII. SERVICE/WARRANTY INFORMATION (continued)

NOTE: Examples of leak detection fluids are

- bubble method
- fluorescent method agents

If a leak is suspected, all naked flames shall be removed/extinguished.

If a leakage of refrigerant is found which requires brazing, all of the refrigerant shall be recovered from the system, or isolated (by means of shut off valves) in a part of the system remote from the leak. Removal of refrigerant shall be according to the removal & evacuation section below.

REMOVAL & EVACUATION

When breaking into the refrigerant circuit to make repairs- or for any other purpose - conventional procedures shall be used. However, for flammable refrigerants it is important that best practice be followed, since flammability is a consideration. The following procedure shall be adhered to:

- safely remove refrigerant following local and national regulations;
- purge the circuit with inert gas;
- evacuate
- purge with inert gas;
- open the circuit by cutting or brazing.

The refrigerant charge shall be recovered into the correct recovery cylinders if venting is not allowed by local and national codes. For appliances containing flammable refrigerants, the system shall be purged with oxygen- free nitrogen to render the appliance safe for flammable refrigerants. This process might need to be repeated several times. Compressed air or oxygen shall not be used for purging refrigerant systems .

For appliances containing flammable refrigerants, refrigerants purging shall be achieved by breaking the vacuum in the system with oxygen-free nitrogen and continuing to fill until the working pressure is achieved, then venting to atmosphere, and finally pulling down to a vacuum. This process shall be repeated until no refrigerant is within the system (optional for A2L). When the final oxygen-free nitrogen charge is used, the system shall be vented down to atmospheric pressure to enable work to take place.

Ensure that the outlet for the vacuum pump is not close to any potential ignition sources and that ventilation is available.

VIII. b - SPARE PARTS INFORMATION

To purchase replacement parts or to speak to service support for Traulsen units please contact our Ft. Worth facility by phone at 800-825-8220 or fax to 817-740-6748 (parts) or 817-740-6757 (service).

Note: When calling for spare parts or service support, please make sure you have model and serial number of unit available.

MODEL NUMBER		827320M1-010																									
S/N		T01500018																									
REFRIGERANT / REFRIGERANTS / REFRIGERANT <table border="1"> <tr> <td>REFRIG (R600a)</td> <td>0.12kg</td> <td>0.4oz</td> <td>2.08 Lb (238.3 g)</td> </tr> <tr> <td>REF PWRG (R600a)</td> <td>100psi</td> <td>3.45 MPa (3.45 MPa)</td> <td></td> </tr> <tr> <td>REFRIG (R410A)</td> <td>200psi</td> <td>3.45 MPa (3.45 MPa)</td> <td></td> </tr> <tr> <td>REF PWRG (R410A)</td> <td>0.8kg</td> <td>2.20kg</td> <td>4.85MPa (4.85MPa)</td> </tr> <tr> <td>REF PWRG (R410A)</td> <td>100psi</td> <td>3.45MPa (3.45MPa)</td> <td></td> </tr> <tr> <td>REF PWRG (R410A)</td> <td>200psi</td> <td>3.79MPa (3.79MPa)</td> <td></td> </tr> </table>				REFRIG (R600a)	0.12kg	0.4oz	2.08 Lb (238.3 g)	REF PWRG (R600a)	100psi	3.45 MPa (3.45 MPa)		REFRIG (R410A)	200psi	3.45 MPa (3.45 MPa)		REF PWRG (R410A)	0.8kg	2.20kg	4.85MPa (4.85MPa)	REF PWRG (R410A)	100psi	3.45MPa (3.45MPa)		REF PWRG (R410A)	200psi	3.79MPa (3.79MPa)	
REFRIG (R600a)	0.12kg	0.4oz	2.08 Lb (238.3 g)																								
REF PWRG (R600a)	100psi	3.45 MPa (3.45 MPa)																									
REFRIG (R410A)	200psi	3.45 MPa (3.45 MPa)																									
REF PWRG (R410A)	0.8kg	2.20kg	4.85MPa (4.85MPa)																								
REF PWRG (R410A)	100psi	3.45MPa (3.45MPa)																									
REF PWRG (R410A)	200psi	3.79MPa (3.79MPa)																									
WARRANTY POWER (WATT) - FOR RESIDENT USE ONLY																											
115V/60Hz/1-Phase/1-Pole/1-Phase																											

NOTES



4401 Blue Mound Road Fort Worth, Texas 76106 (USA)

Phone: 800.825.8220 | Service Fax: 817.740.6757 | E-mail: service@traulsen.com | Website: traulsen.com

Form Number: TR36443 | Part Number: 375-60363-00 (Rev. G) | Revision Date: 01/26

Traulsen © All Rights Reserved