

CLBM-49R
Reach-In Refrigerator
Self-Contained Glass Doors



STANDARD PRODUCT FEATURES

- Bottom-Mounted Refrigeration System Using R-290 Refrigerant
- Stainless Steel Exterior & Interior
- Metal Door Handle(s)
- Positive Seal Self-Closing Door with Stay Open Feature at 110°
- LED Display Control for Accuracy and Easy Monitoring
- Capillary Tube Metering Device
- Three (3) Adjustable, Heavy Duty Epoxy Coated Shelves Per Section
- Set of Four (4) 4" High Casters with Locks Standard on Front Casters
- High-Density, Non-CFC Foamed in Place Polyurethane Insulation
- Easily Accessible Condenser Coil for Cleaning
- Ergonomically Friendly Lower Shelf
- Storage on Top of Cabinet

ACCESSORIES & OPTIONS (Available at Extra Cost)

- + Additional Epoxy Coated Shelves on Pilasters
- + Additional Epoxy Coated Shelves on Pins
- + Set of Four (4) 6" High Legs
- + Set of Four (4) 6" High Casters
- + #1 or Universal Type Trayslides

AVAILABLE CONFIGURATIONS

MODELS

CLBM-49R-FG-LR
CLBM-49R-FG-LL
CLBM-49R-FG-RR

CLBM-49R-HG-LR
CLBM-49R-HG-LL
CLBM-49R-HG-RR

HINGING

Full Glass Doors, Left/Right
Full Glass Doors, Left/Left
Full Glass Doors, Right/Right
Half Glass Doors, Left/Right
Half Glass Doors, Left/Left
Half Glass Doors, Right/Right



Models listed to the applicable UL, CSA and NSF standards by an approved NRTL. Consult the factory or unit data plate for additional information.



ENERGY STAR® Listed Commercial Refrigerator
For full listing visit energystar.gov

Model	Doors	Shelves	Dimensions L x D x H (in.)	Voltage	Amps	NEMA	Ship Wt. (lbs.)	Cu. Ft.
CLBM-49R	2	6	53.75 x 33.5 x 78*	115/60/1	3.6	5 - 15P	790	45.13

*Note: 78 in. height without casters

As continued product improvement is a policy of Traulsen, specifications are subject to change without notice.

Approved by _____ Date _____ Approved by _____ Date _____

MODEL - CLBM-49R

Full Height & Half Height Glass Door Models

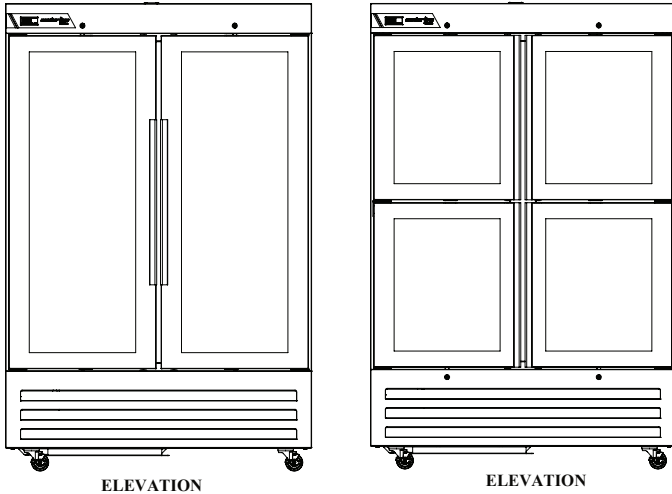

ELEVATION

ELEVATION

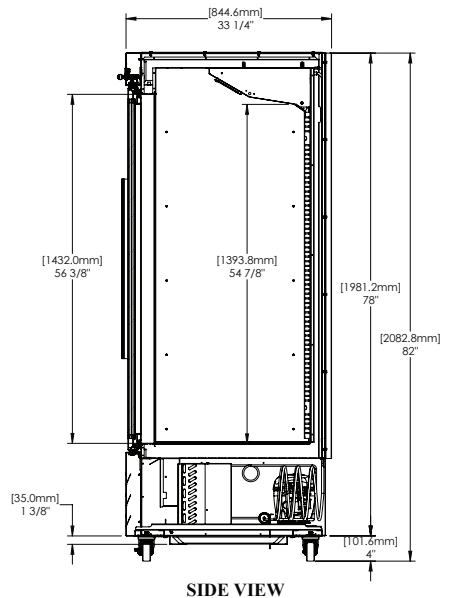

SIDE VIEW

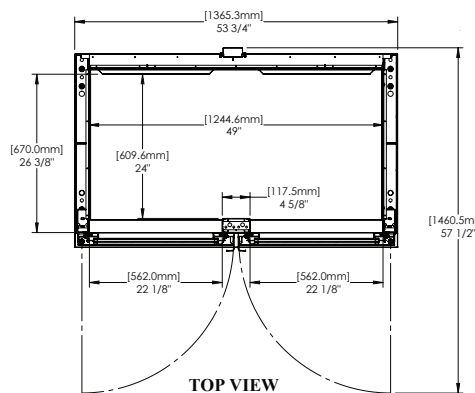

TOP VIEW

SPECIFICATIONS

CONSTRUCTION, HARDWARE, INSULATION

Cabinet exterior & interior are constructed of stainless steel. The exterior cabinet top, back and bottom are constructed of galvanized steel. A set of four (4) 4" high casters are included. Doors are equipped with a gasket protecting retainer and removable plug cylinder locks. The cabinet is insulated with an average of 2-3/8" thick high density, non-CFC, foamed in place polyurethane insulation.

REFRIGERATION SYSTEM

A bottom mounted, self-contained, balanced refrigeration system using environmentally friendly, low GWP R-290 refrigerant is conveniently located behind the one piece louver assembly. It features an easy to clean front facing condenser, capillary tube metering device, and an air-cooled hermetic compressor. A 9' cord and plug is provided. Standard operating temperature is 36°F to 41°F.

CONTROLLER

The easy to use electronic digital control is supplied standard. It includes a 3-Digit LED display, and a Fahrenheit or Celsius temperature scale display capability.

INTERIOR

Standard interior arrangements include three (3) epoxy coated wire shelves per section, mounted on pins. Recommended load limit per shelf should not exceed 150 lbs.

WARRANTY

Both a 6 Year Parts & Labor Warranty and additional 1 Year on Compressor Parts Warranty are supplied standard.

MODELS	CLBM-49R
ELECTRICAL DATA	
Voltage	115/60/1
Full Load Amperes	3.6
REFRIGERATION DATA	
Refrigerant	R-290
Refrigerant Charge oz. (gr)	3.4 (96 g)
BTU/HR' H.P.	2500 1/3
SHIPPING DATA	
Depth Crated in.	40 (101.6 cm)
Height Crated in.	85 (215.9 cm)
Length Crated in.	62 (157.5 cm)
Volume Crated cu. ft.	122 (3454.7 l)
Net Weight lbs.	525 (238.1 kg)
Gross Weight lbs.	575 (260.8 kg)

NOTES:

1. BTU/HR based on a 90°F ambient and 20°F evaporator

Equipped with one NEMA 5-15P Plug



CAD and/or Revit Files Available